



**high efficiency compressed
air filters**



AIR VIP

THE REASONS FOR PURCHASING AIR VIP FILTERS

Modern manufacturing industry requires the cleanest, most reliable compressed air supply available. Compromising your compressed air supply can result in a reduction in product quality, affect site safety and can even result in a production line coming to a halt. A modest investment in the AIR VIP range of compressed air filters will pay for itself many times over.

The AIR VIP series meets the requirements of the "PED" 97/23 CE guidelines.

FILTRATION PRINCIPLES

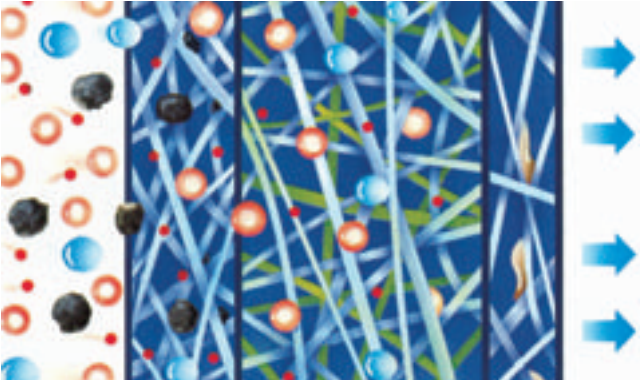

- 1) Direct interception (removal of coarse particles on the outside of the filtration surface).
- 2) Inertial impaction (removal of particles thanks to the tortuous path formed by the microfibres).
- 3) Diffusion (fine particles adhere to the microfibres thanks to "Brownian motion").

THOUSANDS OF HOURS WITH CONSISTENT EFFICIENCY

The ARS range of filter elements in our AIR VIP series are constructed using multiple filter layers, each of which is used for a specific function. The contaminated air (travelling through the cartridge from inside to out) first passes a pre-filtration layer of resin impregnated cellulose fibres, where particles greater than 5 μ are retained.

The use of resin for impregnation guarantees the consistent high strength of the filter material, even in the presence of water.

The air then passes through the second filtration layer, which consists of borosilicate microfibres. This allows the capture of particles with sizes down to 0.01 micron and the formation of condensate droplets, which are conveyed to the outer coalescing layers of the cartridge.

This outer barrier collects the separated droplets of water and oil, allowing them to run down to the bottom of the cartridge and into the bowl of the housing assembly. Although the compressed air elements allow liquids to pass through, the retained solids eventually result in them becoming blocked.



The pleated construction of our ARS range of filter elements provides a very high surface area for the retention of the solid particles (approx. 4-5 times when compared to the conventional rolled filter of most manufacturers), the result is an exceptionally long life & very low pressure drop for the element.

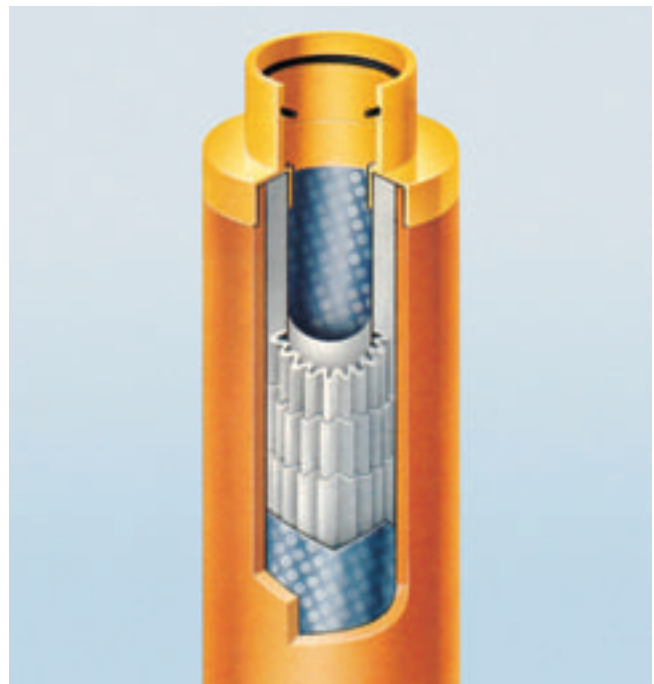

SAFETY SYSTEM

Prevents housing being opened whilst in operation.

EASE OF INSTALLATION

The filter cartridge is retained using a positive seal O-ring. This design feature allows the quick and easy replacement of the filter element, eliminating the need for a tie rod.

COLOUR CODE

The element grade is clearly identified by the use of different colored outer foam sleeves.

AUTOMATIC CONDENSATE DRAIN

The drain has three functions;
Automatic: compressed air operation - normal
Semi-automatic: operates under a no pressure condition
Manual

SPACE REDUCTION

Only 6 cm of clearance under the filter bowl is required during element replacement.

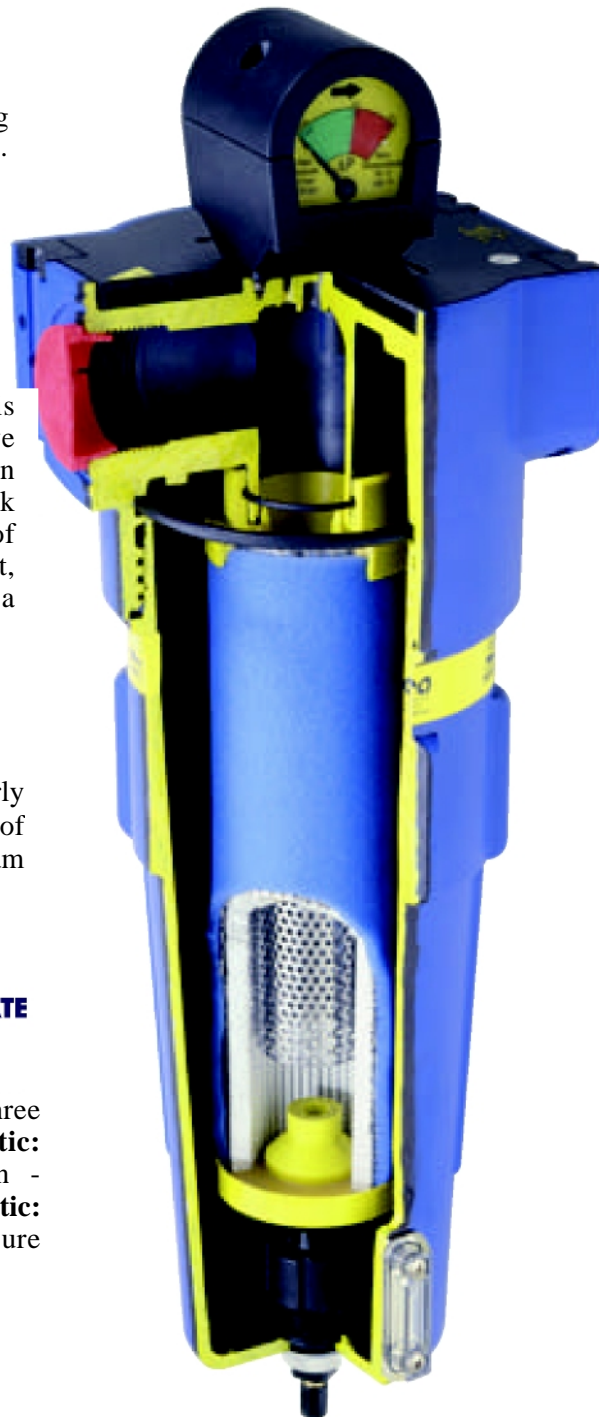

DIFFERENTIAL GAUGE

The differential gauge XAM-200 can be mounted facing either direction and accurately indicates when the filter element needs replacing.

O-RING SEAL

An O-ring seal ensures positive element location and eliminates the possibility of bypass.

PLEATED FILTER ELEMENT

Offers a high filtration surface area, low differential pressure loss and long life.

DUAL LAYER PROTECTION OF BODY

The surface treatment of interior and exterior of the housing assures excellent corrosion resistance.

LEVEL INDICATOR

Displays the presence of collected liquid.

“RM” grade

10 micron
15 ppm

“RF” grade

1 micron
8 ppm
replacement at: 0.6 bar
Air Quality to ISO 8573.1

Compressed air pre-filtration:

Removal of condensate and solid particles, protecting air receivers and refrigerant dryers.

Pre filter for the RB & RA grades.
After filter collecting dust and debris generated by Desiccant dryers.



“RB” grade

1 micron
0.1 ppm

Air Quality to ISO 8573.1
Max. particle size Class 2
Max. oil content Class 2
Clean pressure drop:
60 mbar

replacement at: 0.6 bar

Oil separation and compressed air filtration:

Pre filter for refrigeration driers.
Pre filter for the RA & CA grades.
Vacuum pump inlet protection filter.
Industrial filtration for general purpose air
Removal of particles down to 1µ, coalesced water and oil (liquid).
Max. remaining oil content of 0.1 ppm at 21°C.



“RA” grade

0.01 micron
0.01 ppm

Air Quality to ISO 8573.1
Max. particle size Class 1
Max. oil content Class 1
Clean pressure drop:
80 mbar

replacement at: 0.6 bar

Oil separation and precision filtration of compressed air and gases for the protection of:

Adsorption driers
Sophisticated instrumentation
Spray paint plants
Electronics, food & textiles industries
Removal of particles down to 0.01µ including oil & water aerosols, which provides a max. remaining oil content of 0.01 mg/m³ at 21°C.



“CA” grade

0.003 ppm

Air Quality to ISO 8573.1
Max. particle size Class 1
Max. oil content Class 1
Clean pressure drop:
140 mbar



replacement at: 1000 hours



Elimination of odours and vapours from the compressed air.

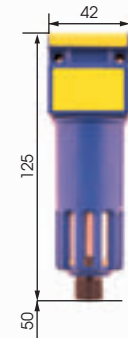
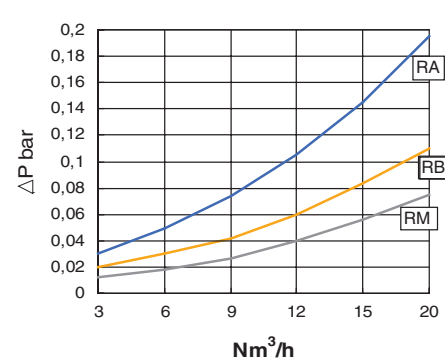
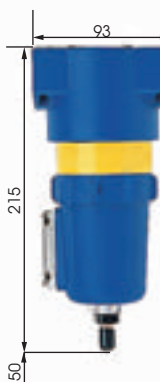
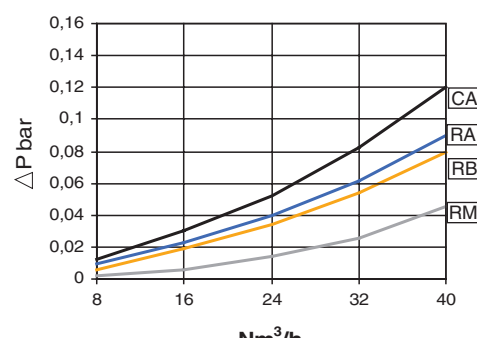
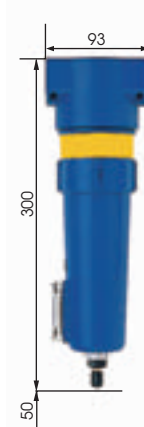
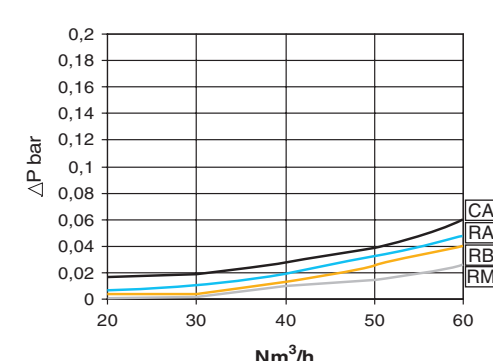

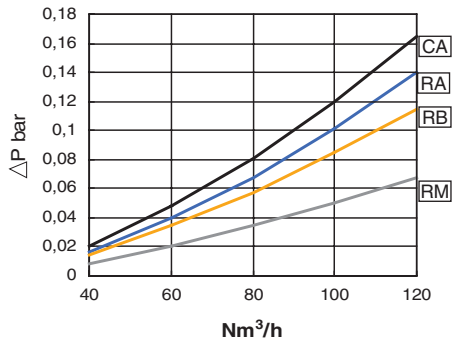

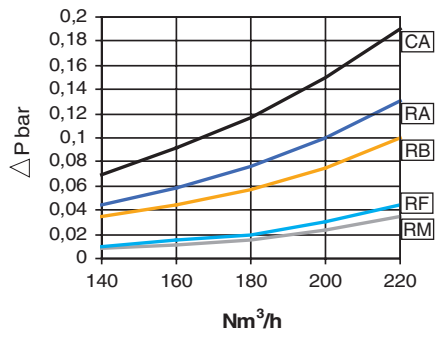
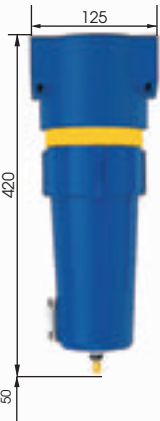
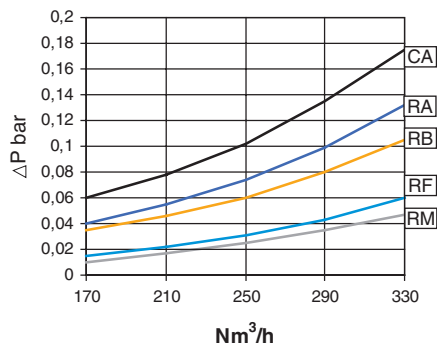
Always to be preceded by the “RA” grade.
Compressed air for:
- food & beverage
- pharmaceutical
- process air
- textiles, electronics
Removal of oil vapour and hydrocarbons, which provides a max. remaining oil content of 0.003 mg/m³ at 21°C.

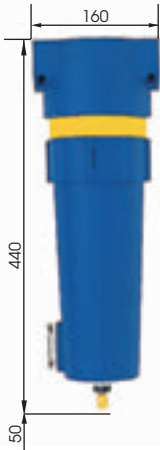
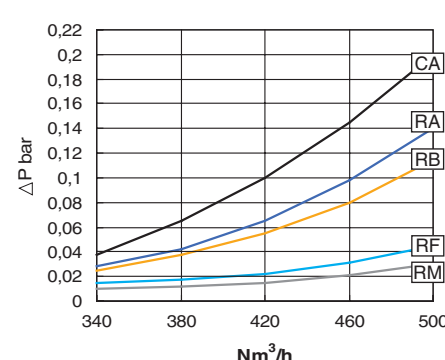
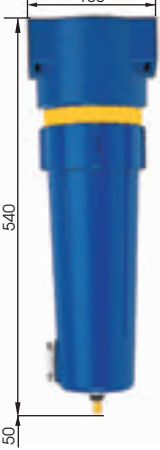
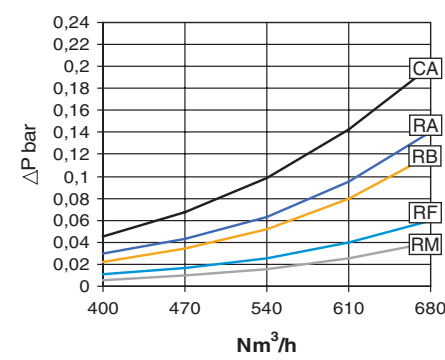

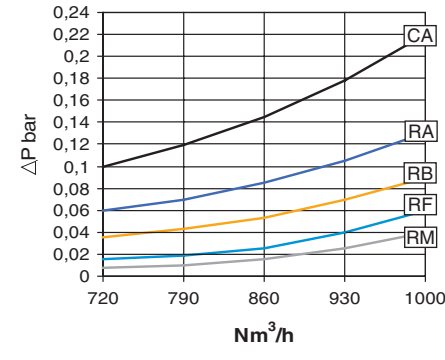
Type P.max: 16 bar T.max: 60°C	Filter element	RM	RB	RA	CA	RF
	Filtration grade <input type="checkbox"/>					
	Residual oil (ppm)	15	0.1	0.01	0.003	-
	Particulate removal (micron)	10	1	0.01	-	1
	Air purity ISO 8573/1	4.-.5	2.-.2	1.-.1	1.-.1	2.-.4
CDF 15 <input type="checkbox"/> 	Connection G 1/4" Material Aluminium Volume 0.15 L. Weight 0.4 Kg.	Values for 7 bar Nm³/h* Scfm				
	Available versions <input type="checkbox"/> 00 = manual valve Filter element 1 off ARS-15 <input type="checkbox"/>	Nominal flow rate 15 9				
		Max flow rate 20 12				
						
CDF 30 <input type="checkbox"/> 	Connection G 1/4" Material Aluminium Volume 0.3 L. Weight 0.7 Kg.	Values for 7 bar Nm³/h* Scfm				
	Available versions <input type="checkbox"/> 00 = manual valve XAD-300 <input type="checkbox"/> 0D = Automatic inner condensate drain XAD-251 <input type="checkbox"/> MD = 0D + differential gauge XAM-100 Accessories available upon request Mounting bracket: XAS-1 Housing connection kit: XAK-1 O-ring seal kit (No.8 O-rings): XAG-1	Nominal flow rate 30 18				
	Filter element 1 off ARS-30 <input type="checkbox"/>	Max flow rate 40 24				
						
CDF 60 <input type="checkbox"/> 	Connection G 3/8" Material Aluminium Volume 0.5 L. Weight 0.8 Kg.	Values for 7 bar Nm³/h* Scfm				
	Available versions <input type="checkbox"/> 00 = manual valve XAD-300 <input type="checkbox"/> 0D = Automatic inner condensate drain XAD-251 <input type="checkbox"/> MD = 0D + differential gauge XAM-100 Accessories available upon request Mounting bracket: XAS-1 Housing connection kit: XAK-1 O-ring seal kit (No.8 O-rings): XAG-1	Nominal flow rate 60 36				
	Filter element 1 off ARS-100 <input type="checkbox"/>	Max flow rate 70 42				
						

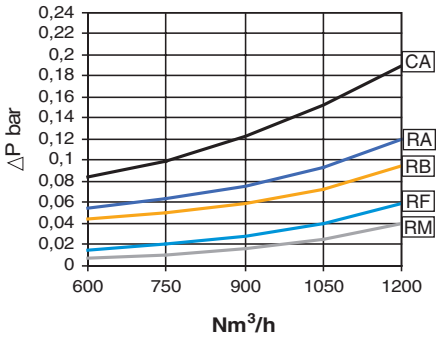
Type	Filter element Filtration grade <input type="checkbox"/>	RM	RB	RA	CA	RF
		Residual oil (ppm)	15	0.1	0.01	0.003
P.max: 16 bar	Particulate removal (micron)	10	1	0.01	-	1
T.max: 60°C	Air purity ISO 8573/1	4.-.5	2.-.2	1.-.1	1.-.1	2.-.4
CDF 100 <input type="checkbox"/> 	Connection G 1/2" Material Aluminium Volume 0.5 L. Weight 0.8 Kg.	Values for 7 bar		Nm³/h*	Scfm	
	Available versions <input type="checkbox"/> 00 = manual valve XAD-300 <input type="checkbox"/> 0D = Automatic inner condensate drain XAD-251 <input type="checkbox"/> MD = 0D + differential gauge XAM-100	Nominal flow rate		100	60	
	Accessories available upon request Mounting bracket: XAS-1 Housing connection kit: XAK-1 O-ring seal kit (No.8 O-rings): XAG-1	Max flow rate		120	72	
	Filter element 1 off ARS-100 <input type="checkbox"/>					
CDF 180 <input type="checkbox"/> 	Connection G 3/4" Material Aluminium Volume 1.2 L. Weight 1.7 Kg.	Values for 7 bar		Nm³/h*	Scfm	
	Available versions <input type="checkbox"/> 00 = manual valve XAD-300 <input type="checkbox"/> 0D = Automatic inner condensate drain XAD-251 <input type="checkbox"/> MD = 0D + differential gauge XAM-100	Nominal flow rate		180	110	
	Accessories available upon request Mounting bracket: XAS-2 Housing connection kit: XAK-2 O-ring seal kit (No.8 O-rings): XAG-2	Max flow rate		220	132	
	Filter element 1 off ARS-180 <input type="checkbox"/>					
CDF 290 <input type="checkbox"/> 	Connection G 1" Material Aluminium Volume 1.6 L. Weight 1.9 Kg.	Values for 7 bar		Nm³/h*	Scfm	
	Available versions <input type="checkbox"/> 00 = manual valve XAD-300 <input type="checkbox"/> 0D = Automatic inner condensate drain XAD-251 <input type="checkbox"/> MD = 0D + differential gauge XAM-100	Nominal flow rate		290	170	
	Accessories available upon request Mounting bracket: XAS-2 Housing connection kit: XAK-2 O-ring seal kit (No.8 O-rings): XAG-2	Max flow rate		330	198	
	Filter element 1 off ARS-290 <input type="checkbox"/>					

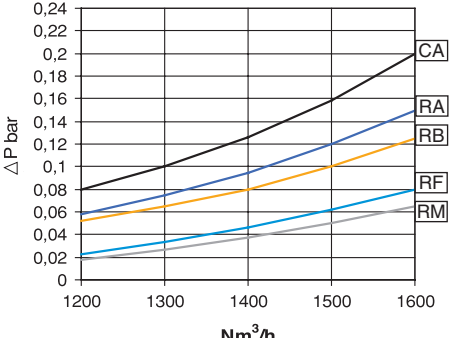
Type	Filter element	RM	RB	RA	CA	RF
	Filtration grade <input type="checkbox"/>					
P.max: 16 bar T.max: 60°C	Residual oil (ppm)	15	0.1	0.01	0.003	-
	Particulate removal (micron)	10	1	0.01	-	1
	Air purity ISO 8573/1	4.-.5	2.-.2	1.-.1	1.-.1	2.-.4
CDF 460 <input type="checkbox"/> 	Connection G 1 - 1/4" Material Aluminium Volume 2.6 L. Weight 3.6 Kg. Available versions <input type="checkbox"/> 00 = manual valve XAD-300 <input type="checkbox"/> 0D = Automatic inner condensate drain XAD-251 <input type="checkbox"/> MD = 0D + differential gauge XAM-100 Accessories available upon request Mounting bracket: XAS-3 Housing connection kit: XAK-3 O-ring seal kit (No.8 O-rings): XAG-3 Filter element 1 off ARS-460 <input type="checkbox"/>	Values for 7 bar Nm³/h* Scfm Nominal flow rate 460 270 Max flow rate 500 300				
	CDF 610 <input type="checkbox"/> 	Connection G 1-1/2" Material Aluminium Volume 3.5 L. Weight 3.9 Kg. Available versions <input type="checkbox"/> 00 = manual valve XAD-300 <input type="checkbox"/> 0D = Automatic inner condensate drain XAD-251 <input type="checkbox"/> MD = 0D + differential gauge XAM-100 Accessories available upon request Mounting bracket: XAS-3 Housing connection kit: XAK-3 O-ring seal kit (No.8 O-rings): XAG-3 Filter element 1 off ARS-610 <input type="checkbox"/>	Values for 7 bar Nm³/h* Scfm Nominal flow rate 610 360 Max flow rate 680 408			
CDF 930 <input type="checkbox"/> 		Connection G 2" Material Aluminium Volume 3.6 L. Weight 5.4 Kg. Available versions <input type="checkbox"/> 00 = manual valve XAD-300 <input type="checkbox"/> 0D = Automatic inner condensate drain XAD-251 <input type="checkbox"/> MD = 0D + differential gauge XAM-100 Accessories available upon request Mounting bracket XAS-4 O-ring seal kit (No.8 O-rings) XAG-4 Filter element 1 off ARS-930 <input type="checkbox"/>	Values for 7 bar Nm³/h* Scfm Nominal flow rate 930 550 Max flow rate 1,000 600			

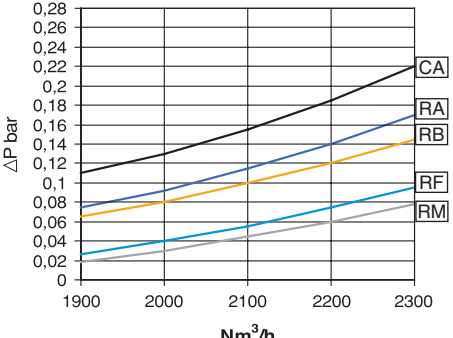
Type	Filter element	RM	RB	RA	CA	RF
	Filtration grade <input type="checkbox"/>					
P.max: 16 bar T.max: 60°C	Residual oil (ppm)	15	0.1	0.01	0.003	-
	Particulate removal (micron)	10	1	0.01	-	1
	Air purity ISO 8573/1	4.-.5	2.-.2	1.-.1	1.-.1	2.-.4
CDF 1050 <input type="checkbox"/> 	Connection G 2-1/2"					
	Material Aluminium					
	Volume 4.5 L.					
	Weight 6.1 Kg.					
	Available versions					
	<input type="checkbox"/> 00 = manual valve XAD-300					
	<input type="checkbox"/> 0D = Automatic inner condensate drain XAD-251					
	<input type="checkbox"/> MD = 0D + differential gauge XAM-100					
	Accessories available upon request					
	Mounting bracket XAS-4 O-ring seal kit (No.8 O-rings) XAG-4					
	Filter element					
	1 off ARS-1050 <input type="checkbox"/>					
		Values for 7 bar	Nm³/h*	Scfm		
		Nominal flow rate	1,050	620		
		Max flow rate	1,200	720		
						
CDF 1500 <input type="checkbox"/> 	Connection DN 80					
	Material Aluminium					
	Volume 8 L.					
	Weight 22 Kg.					
	Available versions					
	<input type="checkbox"/> 00 = Manual valve XAD-300					
	<input type="checkbox"/> 0D = Automatic outer condensate drain XAD-651					
	<input type="checkbox"/> MD = 0D + diff. gauge XAM-100					
	Filter element					
	1 off ARS-1400 <input type="checkbox"/>					
		Values for 7 bar	Nm³/h*	Scfm		
		Nominal flow rate	1,500	900		
		Max flow rate	1,600	960		
						
CDF 2200 <input type="checkbox"/> 	Connection DN 80					
	Material Aluminium					
	Volume 16 L.					
	Weight 28 Kg.					
	Available versions					
	<input type="checkbox"/> 00 = Manual valve XAD-300					
	<input type="checkbox"/> 0D = Automatic outer condensate drain XAD-651					
	<input type="checkbox"/> MD = 0D + diff. gauge XAM-100					
	Filter element					
	2 off ARS-1400 <input type="checkbox"/>					
		Values for 7 bar	Nm³/h*	Scfm		
		Nominal flow rate	2,200	1,320		
		Max flow rate	2,300	1,380		
						

Sizing table

Series of carbon steel housings	Filter element Filtration grade \square		RM	RB	RA	CA	RF
	Residual oil (ppm)		15	0.1	0.01	0.003	-
	Particulate removal (micron)		10	1	0.01	-	1
	Air purity ISO 8573/1		4.-.5	2.-.2	1.-.1	1.-.1	2.-.4

Type	Referred to 7 bar		Conn. size	Dimensions				Fig.	Weight Kg.	Filter element	
	Nm ³ /h	Scfm		A	B	C	D			Type	N°
ACF -1500-00	1,400	820	DN 80	440	693	350	155	1	45	ARS-1400 \square	1
ACF -2200-00	2,200	1,299	DN 80	440	1020	700	155	1	60	ARS-1400 \square	2
ACF -3750-00	3,600	2,100	DN 100	600	1340	800	260	1	95	ARS-1250 \square	3
ACF -5800-00	5,800	3,400	DN 150	600	1650	500	520	2	190	ARS-1400 \square	6
ACF -8600-00	8,600	5,100	DN 150	700	1800	500	540	3	230	ARS-1400 \square	8
ACF-14000-00	14,000	8,250	DN 200	750	1900	500	580	3	300	ARS-1400 \square	12
ACF-19200-00	19,200	11,300	DN 250	800	1950	500	630	3	380	ARS-1400 \square	16
ACF-22000-00	22,000	12,950	DN 250	850	2000	500	650	3	430	ARS-1400 \square	20
ACF-33000-00	33,000	19,400	DN 300	950	2150	500	700	3	560	ARS-1400 \square	30

Flow rate values stated are for 7 bar, for different line pressures, use the correction factors below.

Pressure on line bar g	1	2	3	4	5	6	7	8	9	11	12	13	14	15	16
Correction factor	0.38	0.53	0.65	0.75	0.80	0.90	1	1.10	1.15	1.25	1.30	1.35	1.40	1.45	1.50

GENERAL NOTE - The performance indicated in the flow rate diagrams is referred to a 20 °C temperature with a saturated filter element.

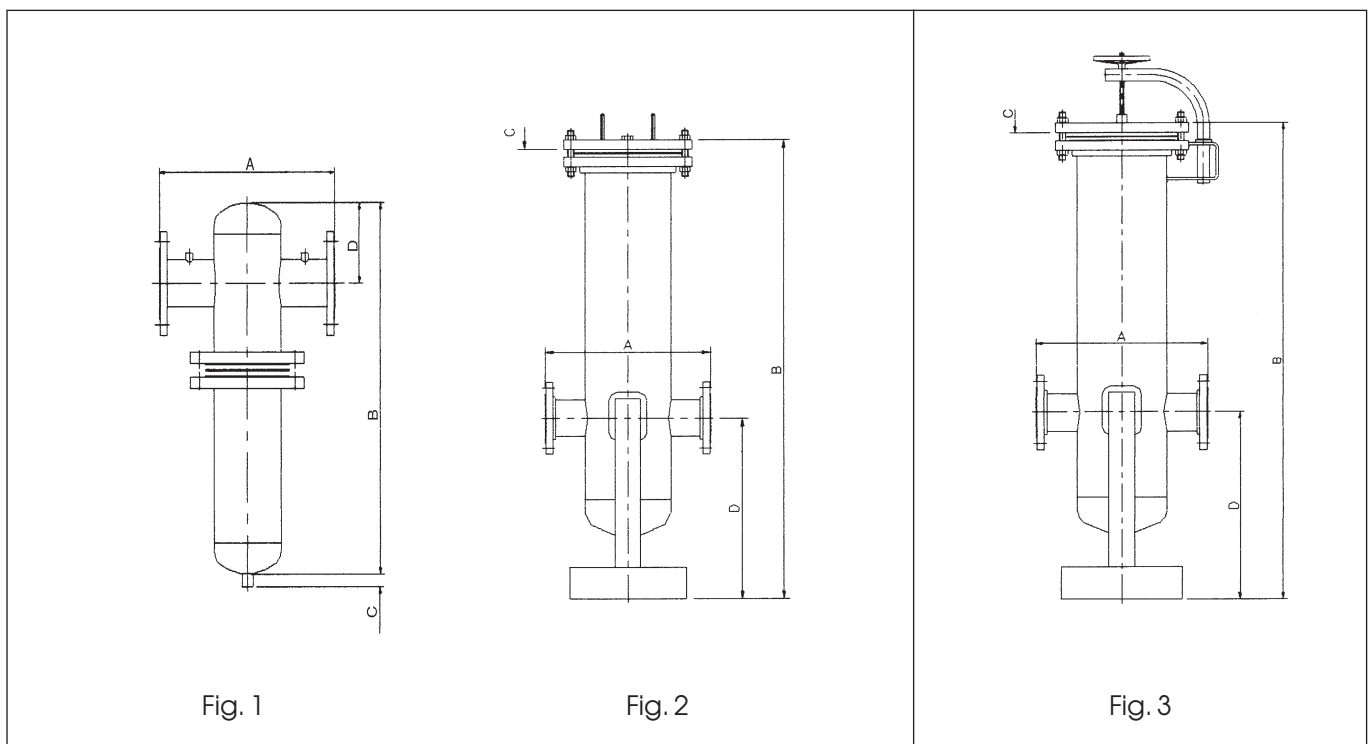

TYPICAL APPLICATIONS FOR COMPRESSED AIR SYSTEMS

FOR GENERAL USE

Air purity ISO 8573-1 : class 2.-.2

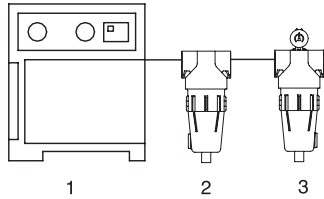

2- Prefilter grade **RM**

WITH DEW POINT AT +3°C

Air purity ISO 8573-1 : class 1.4.1

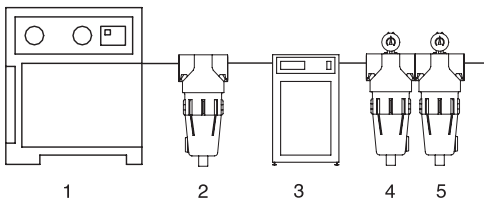

3- **DRY-VIP** drier
4- Filter grade **RB**
5- Filter grade **RA**

WITH DEW POINT FROM -20°C to -40°C

Air purity ISO 8573-1 : class 1.2.1 or 1.1.1

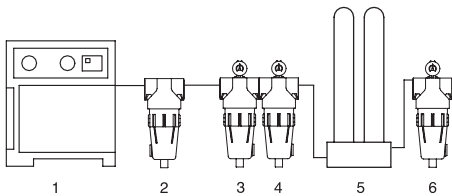

2- Prefilter grade **RM**
5- **DRY PLUS** adsorption drier
6- After filter grade **RF**

PURE AND STERILE AIR – POINT OF USE

Air purity ISO 8573-1 : class 1.-.1

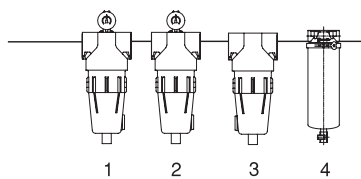

4 – Sterile filter grade **SL**

MODULAR SYSTEM

INSTALLATION IN SERIES

Mounting kits are available which enables the installation of several filters in series. The design of our compact assembly allows the use of a multi stage system to be used where minimal space is available.



DESIGN OF EACH DETAIL



EASY INSTALLATION

All the components, mounting brackets, clamps and differential gauges are easily assembled.

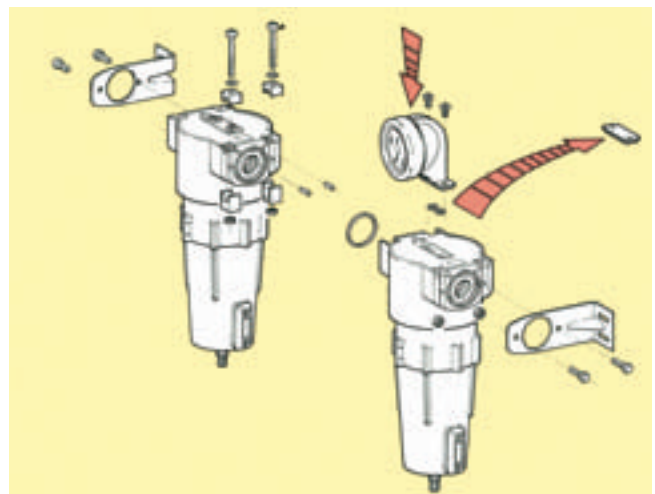

ACCESSORIES

XAC -21-230

Standard voltage: 230V-50/60
Operating pressure: 0.8-16 bar
Operating temperature: +1/60°C
Weight: 700 gr.

The automatic condensate drain XAC-21-230 is used for the removal of condensate & oil emulsion from the compressed air system, without needlessly wasting expensive energy. The XAC-21 uses a capacitive level sensor which prevents the venting of compressed air during operation.



XAM-100

Bourdon valve operation
Max operating pressure: 16 bar
Max operat. temperature: 60°C
Scale: 0-1.4 bar

XAM-200

Max operative pressure: 16 bar
Max operat. Temperature: 70°C
Scale: 0-0.7 bar

XAM-100 differential gauge measures the pressure difference between the inlet and outlet of the filter assembly, in a range from 0 to 1.4 bar. The scale centrally set at "0" allows the mounting on both side of the filters. **XAM-200**, differential pressure gauge identifies the convenient time for the change out of the filter element. The pressure gauge has on both side a scale in two colors in a range from 0 to 0.7 bar. No pressure behind lens and special membrane gaskets provide XAM 200 a great safety and accuracy. **XAM-200EC** series includes the remote control interface.



XAD-251

Operating pressure: 0.6-16 bar
Operating temperature: +5 / 80°C
Weight: 65 gr.

The automatic float condensate drain is specified from models CDF -30 to the CDF-1050. The drain can run in 3 different ways:

Automatic: the elevation of the float opens the pilot valve, then the compressed air opens the shutter to allow the liquid to discharge.

Semi-automatic: to avoid liquid discharging when the pressure drops under 0.6 bar the condensate drain opens, venting the collected liquid.

Manual: the liquid is discharged by rotating the brass ratchet anti-clockwise.



XAD-651

Operating pressure: 0-16 bar
Operating temperature: +5 / 80°C
Weight: 0.6 Kg.

Automatic float condensate drain with aluminium body for installation where large amounts of condensate need to be discharged from the air line. The float mechanism is manufactured from stainless steel.



TECHNICAL FEATURES

Type	Max. flow rate		Nominal flow rate		Conn.	Pressure Max bar	Q.ty	Replacement elements
	Nm ³ /h	Scfm	Nm ³ /h	Scfm				
CDF-15-00	20	12	15	9	1/4" GAS	16	1	ARS-15
CDF-30-MD	40	24	30	18	1/4" GAS	16	1	ARS-30
CDF-60-MD	70	42	60	36	3/8" GAS	16	1	ARS-100
CDF-100-MD	120	72	100	60	1/2" GAS	16	1	ARS-100
CDF-180-MD	220	132	180	110	3/4" GAS	16	1	ARS-180
CDF-290-MD	330	198	290	170	1" GAS	16	1	ARS-290
CDF-460-MD	500	300	460	270	1 1/4" GAS	16	1	ARS-460
CDF-610-MD	680	408	610	360	1 1/2" GAS	16	1	ARS-610
CDF-930-MD	1,000	600	930	550	2" GAS	16	1	ARS-930
CDF-1050-MD	1,300	780	1,050	620	2 1/2" GAS	16	1	ARS-1050
CDF-1500-MD	1,600	960	1500	900	DN80 PN16	16	1	ARS-1400
CDF-2200-MD	2,300	1,380	2200	1,320	DN80 PN16	16	2	ARS-1400
ACF-1500-00	1,600	960	1,500	900	DN 80	16	1	ARS-1400
ACF-2200-00	2,300	1,380	2,200	1,320	DN 80	16	2	ARS-1400
ACF-3750-00	3,750	2,280	3,600	2,160	DN 100	10	3	ARS-1250
ACF-5800-00	6,000	3,600	5,800	3,480	DN 150	10	6	ARS-1400
ACF-8600-00	8,800	5,280	8,600	5,160	DN 150	10	8	ARS-1400
ACF-14000-00	14,500	8,700	14,000	8,400	DN 200	10	12	ARS-1400
ACF-19200-00	19,500	11,700	19,200	11,520	DN 250	10	16	ARS-1400
ACF-22000-00	22,500	13,500	22,000	13,200	DN 250	10	20	ARS-1400
ACF-33000-00	33,600	20,160	33,000	19,800	DN 300	10	30	ARS-1400

Correction factor - for specific line pressures, multiply the above flow rates by the corresponding correction factor below

Pressure on line bar g	1	2	3	4	5	6	7	8	9	10	11	12	13	14	15	16
Correction factor	0.38	0.53	0.65	0.75	0.80	0.90	1	1.10	1.15	1.20	1.25	1.30	1.35	1.40	1.45	1.50

Data contained in this bulletin are informative and subject to change without notice.
User is responsible for determining whether the product is fit for particular purpose and suitable for User's method of application.



Bea Technologies SpA
Via Newton, 4 I-20016 Pero (Milano) Italy
Tel: +39-02339271 Fax: +39-023390713 info@bea-italy.com