



GIRAIR SYSTEM

**PIPES AND FITTINGS
FOR COMPRESSED AIR**

ISSUE
JUNE 2002

TECHNICAL
DOCUMENTATION



GIRPI

safety for your pipeworks

CERTIFICATION



N° QUAL/1995/3526

Le Système Qualité adopté par :
The Quality System developed by :

GIRPI

pour les activités suivantes :
for the following activities :

**FABRICATION PAR INJECTION, FACONNAGE ET VENTE DE PIECES
ET ACCESSOIRES EN MATIERES PLASTIQUES
POUR LE BATIMENT ET L'INDUSTRIE.**

**MANUFACTURING BY INJECTION MOULDING, SHAPING AND SALES
OF PLASTIC PARTS AND ACCESSORIES FOR BUILDING AND INDUSTRY.**

exercées sur le(s) site(s) suivant(s) :
carried out in the following location(s) :

Rue Robert Ancel BP 36 F-76700 HARFLEUR

a été évalué et jugé conforme aux exigences de la norme :
has been assessed and found to conform to the requirements of the standard :

ISO 9002 (1994)

Le certificat correspondant a été délivré dans les conditions d'application fixées par AFAQ le :
The corresponding certificate has been delivered under AFAQ application rules on :

2001-05-02

(année-mois-jour)

*Il est valable jusqu'au**
*It is valid until**

2003-12-14

(year-month-day)

LE PRÉSIDENT DU COMITÉ DE CERTIFICATION
THE PRESIDENT OF THE CERTIFICATION COMMITTEE

P. LATY

LE DIRECTEUR GÉNÉRAL D'AFAQ
THE MANAGING DIRECTOR OF AFAQ

O. PEYRAT

LE REPRÉSENTANT DE L'ENTREPRISE
ON BEHALF OF THE FIRM

M. DIVANACH

*Sauf suspension notifiée entre temps par AFAQ à l'entreprise désignée ci-dessus. Le présent document n'a donc qu'une valeur indicative. Seule fait foi la base de données des certificats AFAQ accessible à l'adresse internet : <http://www.afaq.org>
L'organisation AFAQ est conforme aux normes internationales en vigueur (guide ISO/IEC 62 - norme EN 45012). Les accréditations détenues par AFAQ et ses filiales sont disponibles à l'adresse internet : <http://www.afaq.org/accreditations>
*Excepting notification by AFAQ to the above mentioned company of its suspension. This document is for information purposes only. For up-to-date information, the only official source is the AFAQ certificate database at <http://www.afaq.org>
The AFAQ organization complies with the international standards in force (62 ISO/IEC Guide - EN 45012 standard). Information on the accreditations held by AFAQ and its subsidiaries is available at: <http://www.afaq.org/accreditations>

AFAQ - 116, AVENUE ARISTIDE BRIAND - BP 40 / F-92224 BAGNEUX CEDEX FRANCE



TECHNICAL DOCUMENTATION SUMMARY

0.0

| Titles | Technical sheet number |
|-----------|------------------------|
| • Summary | 00 |

General :

| | |
|------------------------|-----|
| • Applications | 1.1 |
| • Benefits | 1.2 |
| • Characteristics | 1.3 |
| • Operating conditions | 1.4 |

| | |
|------------------------------|------------|
| Range : • Descriptive | 2.1 to 2.2 |
|------------------------------|------------|

Work on pipes and fittings :

| | |
|---------------------------------------|------------|
| • Tools | 3.1 |
| • Cold welding method | 3.2 to 3.3 |
| • Recommendations | 3.4 to 3.5 |
| • Control, testing and implementation | 3.6 |

Contraction expansion :

| | |
|----------------------------|------------|
| • Phenomenon - Calculation | 4.1 |
| • Consequences - Solutions | 4.2 to 4.3 |

Environnement :

| | |
|---------------------|------------|
| • Monoklip brackets | 5.1 to 5.2 |
| • Special cases | 5.3 |

Pressure losses :

| | |
|--|------------|
| • Admissible flow rates and pressures losses | 6.1 to 6.4 |
|--|------------|

Technical sheets :

| | |
|----------------------|--------------|
| • Pipes | 7.1 |
| • Fittings | 7.2 to 7.11 |
| • Brackets | 7.12 |
| • Valves Ø 16 to 63 | 7.13 to 7.14 |
| • Valves Ø 75 to 110 | 7.15 to 7.16 |

| | |
|-------------------------------------|------------|
| Chemical resistance charts : | 8.1 to 8.4 |
|-------------------------------------|------------|

Specifications

**GENERAL CHARACTERISTICS
APPLICATIONS**

GIRPI is a specialist of technical network's and belongs to an international group that is present in 35 countries.

In order to complete its range designed for the carrying of industrial liquids under pressure **GIRPI** proposes the GIRAIR® system optimised to carry gases for the following applications :

- Distribution of compressed air
- Distribution of neutral industrial gases like nitrogen
- Under vacuum network until - 0,7 relative bars

Among numerous advantages of using GIRAIR®, it must be emphasised :

SECURITY OF THE NETWORK

Gases are compressible and thus dangerous if the bursting of a pipe occur's. This is the reason why the GIRAIR® system was created with an alloy of ductile vinyl. Owing to that it has an excellent behaviour in case of a mechanical impact.

It has a huge resistance to impact and moreover its ductility enable's it to have a behaviour highly ductile and thus unable a bursting of a pipe that could injures somebody.

The manufacturing process is highly innovating with coextrusion which make the superficial part of the pipes resistant to ageing and atmospheric attacks : that is why we can guarantee without the shadow of a doubt the very long duration and efficiency of our products.

ENERGY SAVING

Risks of leaks are eliminated as there is neither internal nor external corrosion and because of the waterproofness of our products. GIRAIR® system enables you to save energy.

QUALITY OF THE AIR WHERE IT IS USED

Indeed the choice of the compressor, dryer and filtration enable to guarantee a very good quality of the air at the entry of the network. The distribution system must not alter this quality.

The inertia of the GIRAIR® circuit, thanks to the absence of condensation and corrosion, does not generate the deterioration of the quality of the air.

- ❑ **Corrosion resistant :** GIRAIR® is neither attacked by the atmospheric agents (humid air, aggressive environment), nor by the condensates (no phenomenon of hydrolysis). The networks are perennial and without leaks.
- ❑ **Descriptive :** The blue colouring in the composition of the pipes enables easy identification of the compressed air network. The installation of the layers of protection against corrosion as well as the painting of conventional is not necessary.
- ❑ **Strength-Impact resistance :** The GIRAIR® system presents an excellent ductile behaviour in case of a mechanical impact.
- ❑ **Resistance to compressor oils :** The components of the GIRAIR® system material feature excellent resistance to the usual compressor oils (see sheets 8.1 to 8.4).
- ❑ **Self extinguishing :** In case of fire the GIRAIR® system does not feed the fire or propagate the flame (rated M2 by CSTB).
- ❑ **More efficient flow rates :** A smooth surface condition combined with insensitivity to corrosion provides a better air flow rate with a flow section equal to that of metal pipes, which does not diminish in time.
- ❑ **Installation :** A quick and easy to install system :
 - Light weight.
 - Simple tools.
 - No flame.The GIRAIR® system is simple to install.

The GIRAIR® system was approved by VERITAS within the framework of a new technical investigation (enquête technique nouvelle VERITAS).

1. PHYSICAL CHARACTERISTICS

| Characteristics | Standards | Units | Values |
|--|-----------------------------------|-------------------|--------|
| Density | NF T 54-022 – ISO 1183/3514 | kg/m ³ | ≈ 1300 |
| Linear expansion coefficient α | ASTM D 696-70 | mm/m°C | 0,095 |
| Water absorption (24 h at 100° C) | NF T 54-023 et ISO 2508 | g/m ² | 2 |
| VICAT softening temperature (load 5 daN) | NF T 51-021 méthode B ISO/R306 | °C | ≥ 73 |
| Fier classification | | – | M2 |
| Termical conductivity | ASTM C177-76 | W/m°k | 0,17 |

2. MECHANICAL CHARACTERISTICS

| Characteristics | Standards | Units | Mean values |
|--|---------------------|-------------------|------------------|
| Breaking tensile strength, measured on pipe. | NF T 54-026 | MPa | 31 |
| Breaking elongation | NF T 54-026 | % | > 100 |
| Brending elasticity modulus | NF T 54-026 | MPa | > 1700 |
| IZOD impact performance | NF T 51-911 | J/cm ² | > 2,5 |
| Resistance to static pressure | | | |
| Pipes - fittings time ≥ 1 h | NF T 54-042/035/025 | bar | 4,2 x PN |
| Resistance to alternating pressure | | | |
| (On fittings and glued jointings) Pressure : mini 20 bar/max 50 bar Ø 16 to 90 = fréquence 1 HZ Ø 110 = frequency 0,42 HZ | T 54-094 | cycles cycles | ≥ 5000 ≥ 2500 |

1 MPa = 10 bar

3. DIMENSIONAL CHARACTERISTICS

The GIRAIR® pipes and fittings are manufactured and tested according to the dimensional requirements indicated in the French Standard :

- for pipes NF T54-002 and T 54-003
- for fittings NF T54-028 and T 54-040

GENERAL CHARACTERISTICS

OPERATING CONDITIONS

1.4

2002



PMS : Maximum Working Pressure

■ WORKING PRESSURE AND TEMPERATURE :

The 12,5 bar pressure is a **maximum operating pressure** applicable at pipe wall temperature (fluid + ambient) between -20°C and +25°C.

An increase in the temperature causes a reduction in the mechanical strength of the GIRAIR® system components which reduces their resistance to pressure.

When the fluid or the ambient temperature is higher than 25°C, the **Maximum Working Pressure (MWP)** must be determined via the graph below.

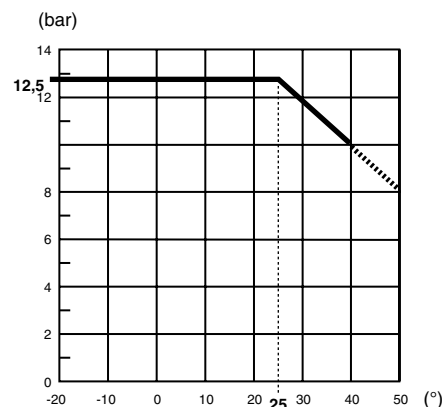

■ WORKING LIFETIME :

The working pressure and temperature indicated in the following tables are determined for a working life of **50 years without interruption.**

Working pressures according to working temperature are figured out by using regression curves as per standard NF T 54-091.

■ TESTING PRESSURE

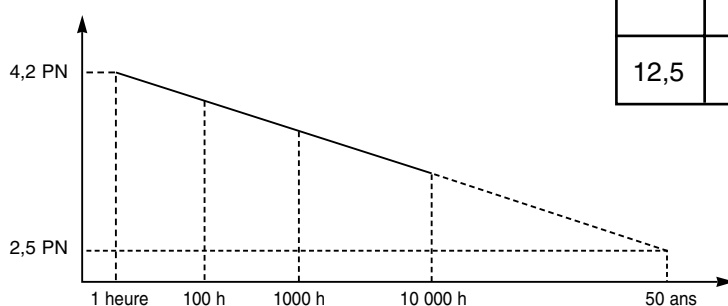



















| PN | Testing Pressure 1 h (20°C) |
|------|--------------------------------|
| 12,5 | 52,5 bar |

A pressure pipework can be classified as PN 12,5 (with a safety factor of 2,5 after 50 years) if it can tolerate during one hour a pressure equal to 4,2 times this PN.

The readings for the breaking pressures for GIRAIR® range, as shown in a straight-line in logarithmic co-ordinates. Considering the safety coefficients, the pressure ratio between 50 years and one hour ranges from 4,2 to 2,5. This straight line is drawn on the basis of the 1 hr, 100 hr, 1 000 hr, 10 000 hr tests, and is the extrapolated to 50 years.

■ GUARANTEES :

- For all applications specified the technical documentation, regardless of pipe diameters, GIRPI has an insurance to guarantee installations which are carried out in accordance with its own general recommendations, and which respect the conditions of use (temperature, pressure, the nature of gas) specified above.

| Description | Ref. | Diameter in mm | | | | | | | | | |
|--|---------|----------------|------|----------|----------------|----------------|----------------|----------------|----------------|----------------|----------------|
| | | 16 | 20 | 25 | 32 | 40 | 50 | 63 | 75 | 90 | 110 |
| GIRAIR PIPE | TUBGA | | | | | | | | | | |
| SOCKET  | GAMA | | | | | | | | | | |
| 90° ELBOW  | GA4M | | | | | | | | | | |
| 45° ELBOW  | GA8M | | | | | | | | | | |
| 90° BEND  | GA4C | | | | | | | | | | |
| CROSS 90°  | GAXT | | | | | | | | | | |
| 180° DROP BEND  | GA2C | | | | | | | | | | |
| 45° STREET ELBOW  | GA8M.MF | | | | | | | | | | |
| TEE EQUAL  | GATE | | | | | | | | | | |
| TEE REDUCED  | GATR | | 16 | 16 20 | 16 20 25 | 20 25 32 | 25 32 40 | 25 32 40 | 25 32 40 | 25 32 40 | 32 40 50 |
| REDUCING BUSH  | GARS | | 16 | 20 | 25 | 32 | 40 | 50 | 63 | 75 | 90 |
| REDUCERS  | GARD | | | 16 | 20 | 25 | 32 | 25 32 40 | 32 40 50 | 40 50 63 | 50 63 75 |
| CAP  | GABO | | | | | | | | | | |
| SOCKET UNION  | GA3P | | | | | | | | | | |
| SOCKET x SPIGOT BSP UNION  | GA3F/P | 3/8" | 1/2" | 3/4" | 1" | 1"1/4 | 1"1/2 | 2" | 2"1/2 | | |
| COMPOSITE UNION Female BSP iron/ socket GIRAIR®  | GA3G/F | | 1/2" | 3/4" | 1" | 1"1/4 | 1"1/2 | 2" | | | |
| COMPOSITE UNION Male BSP iron/ socket GIRAIR®  | GA3F/F | | 1/2" | 3/4" | 1" | 1"1/4 | 1"1/2 | 2" | | | |
| COMPOSITE UNION Female BSP brass/ socket GIRAIR®  | GA3G/L | 3/8" | 1/2" | 3/4" | 1" | 1"1/4 | 1"1/2 | 2" | | | |
| COMPOSITE UNION Male BSP brass/ socket GIRAIR®  | GA3F/L | 3/8" | 1/2" | 3/4" | 1" | 1"1/4 | 1"1/2 | 2" | | | |

■ CUTTING

- The roller plastic pipe-cutter

Réf. GIRPI **CT1240** Ø 12 to 40 mm
 Réf. GIRPI **CT1263** Ø 12 to 63 mm
 Réf. GIRPI **CT50110** Ø 50 to 110 mm

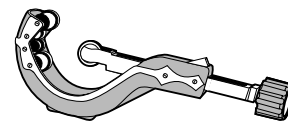

- The chamfering pipe-cutter

This toll cuts and chamfers the pipe after cutting, in one single operation. It is designed to cut the Ø 160 pipes without accessories.

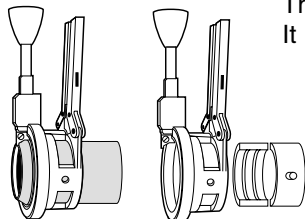

Réf. GIRPI **CTC63** Ø 32 to 63 mm
 Réf. GIRPI **CTC110** Ø 75 to 110 mm

■ TRIMMING - CHAMFERING

After cutting, the pipe must be trimmed inside and a **chamfer must be made on the outside**.

These operations can be performed by means of a 1/2 round bastard file.

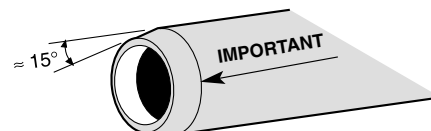

- **Trimming and chamfering cone** : This tool can be used on the pipe, on the other side it chamfers the outside. Réf. GIRPI **CONE 50 U** for pipes Ø 12 to 50 mm



Chamfering tool

This tool chamfers the pipe outside from Ø 32 to Ø 160.

Réf. GIRPI **CHANF160**

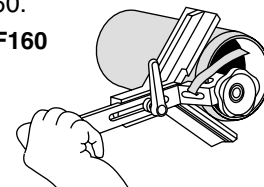

Chamfering pipe cutter (see cutting section).

Trimmer

This reams the inside of pipes of all diameters. Réf. GIRPI **EBAV1** Ø 12 to 160 mm



■ HOLDING TOOLS

Chain vice *

Polyurethane pipe-rests hols the pipe without any damage.

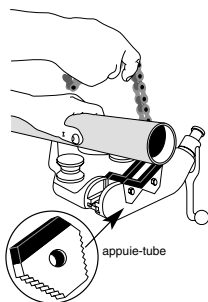

Strap wrench *

Maximum gripping power, with no risk of deforming the pipes or fittings (braided nylon strap).

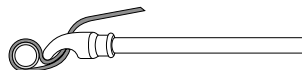

Réf. GIRPI **CLE 160**

Chain bench vice *

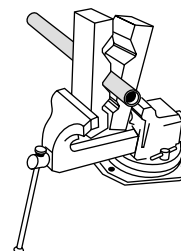
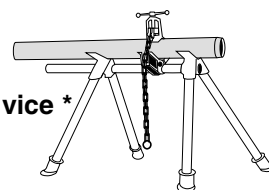

Vice (traditionnal) In this case all the necessary precautions must be taken so that the pipe is neither crushed nor scratched by jaws. For this purpose, a "Hard wood tool" can be cheaply produced. The pipe should be placed in the corresponding notch ; by tightening up the vice the tool clamps the pipe.

* These tools are distributed (among other sellers) by Ets AGI - 75, rue St-Denis - 93300 Aubervilliers - Tél. 01 48 34 91 99.

GENERAL RULES OF INSTALLATION WELDING PROCEDURE

3.2

2002

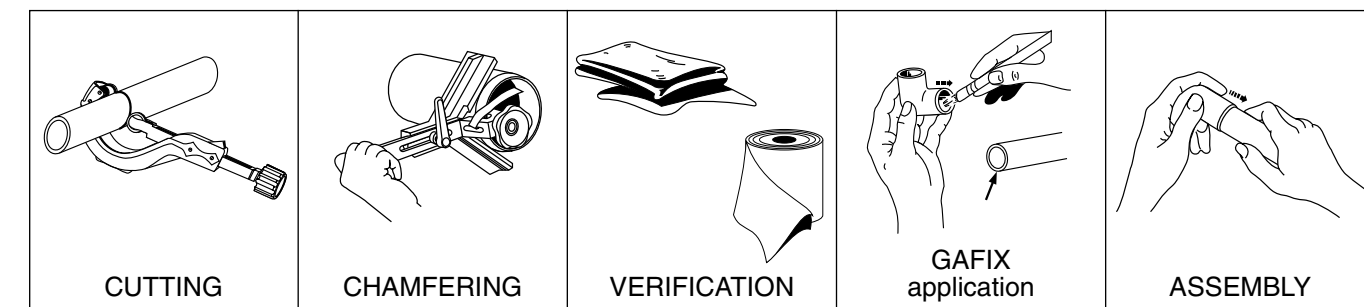

■ CHECKS PRIOR TO COLD WELDING

The priming operation can be replaced by the cleaning of pipes and fittings with a clean cloth if :
the pipes and fittings are clean and dry, the working zone is wholesome otherwise, the priming will be made with D 171 Plus scouring agent to eliminate all traces of fat (finger marks, greasy dirt,...).

Before bonding it is important to make certain checks :

a) on the pipes and fittings : see that they contain no sign of impact, deep scoring, etc...

b) on the adhesive : it must be viscous, homogeneous, with no crusts or foreign matter and should release a strong smell (solvent).

⚠ IMPORTANT

- **Water impairs the adhesive** and subsequently the welding quality. No cold welding will therefore be applied if the parts to be assembled are damp (prior drying required).
- With GIRFIX GA adhesive, the bonding can be applied when the temperature is over + 5° C and under + 35° C. Welding can take place at 0° C ambient temperature with a cement kept at 20° C.
- The atmospheric conditions (temperature, humidity) considerably affect the welding time (drying, evaporation of solvents) of the adhesive.
- At low temperature, the parts when assembled should be held together for 20 to 30 seconds.
- In hot weather, the adhesive should be applied rapidly and the parts immediately jointed.
- So as to avoid evaporation of the solvent contained in the adhesive, the pot must be closed after each solvent welding operation.

■ MARKING OF THE SOCKET LENGTH

- It is useful, in the case of the pipe, to trace on it (using a thick pencil or felt maker) a mark at a distance equal to the corresponding socket depth.

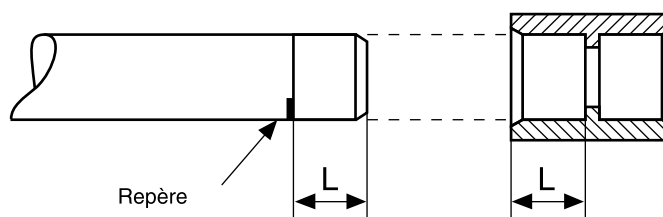

This mark enables :

- 1) to apply the adhesive over the necessary length ;
- 2) to check whether the penetration length of the male end in the socket is correct.

GENERAL RULES OF INSTALLATION WELDING PROCEDURE

3.3

■ COLD WELDING



- Check that the pipe has been done, then apply the adhesive.
- **GAFIX** adhesive must be used.

- To apply the adhesive, use a suitable brush. Do not use : your fingers, a piece of wood or any other utensil ; dipping the pipe or couplings in the cement is prohibited (this way of doing things creates a bead of cement at the bottom of the socket and in small diameters a film obstructing the bore).

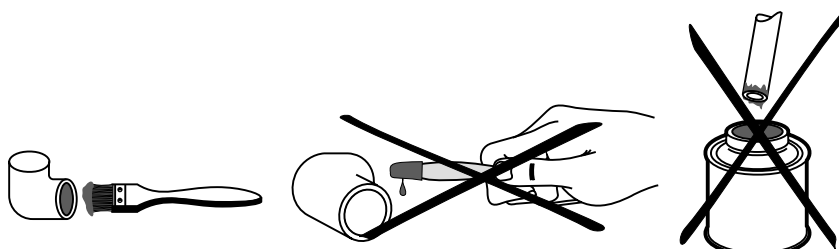

- Apply the cement moderately (in a thin coat) over the whole (the female) interlock length and over the whole length of the male end (marked on pipe). The cement should be applied in 2 thin cross-coats, the second coat being in the longitudinal direction. See NF T 54-035 standard.

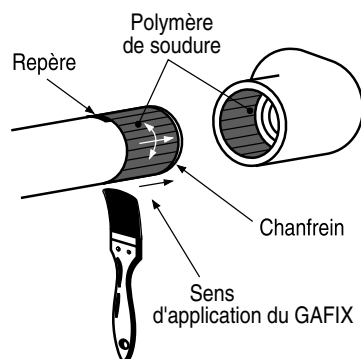

Owing to the standardized tolerance ranges of the male ends and the sockets, some gap may appear. In this case, double welding must be carried out. This consists in coating the male end once, then the socket and the male end a second time, then joint them.

■ JOINTING

- Immediately after applying the cement, joint the two right home (as far as the marks previously traced) pushing longitudinally and, above all, without twisting.
- Hold for 5 seconds.

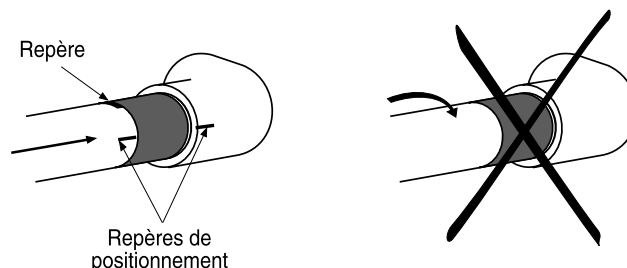

NB : In certain cases it is necessary to mark the position of the one element in relation to the other (see sketch above).

WORK ON PIPES AND FITTINGS RECOMMENDATIONS

3.4

2002



■ **DRYING TIME** With GAFIX cement, the drying times before pressure tests are the following :

| Ø (en mm) | 16 - 63 | 75 - 110 | 16 - 63 | 75 - 110 |
|----------------------------|------------------------------------|----------|--------------------------------------|----------|
| Ambient temperature | For 6 bar pressure test, at | | for testing at 12,5 bar, 20°C | |
| 5 to 10°C | 2 h | 4 h | 4 h | 24 h |
| 10 to 35°C | 1 h | 2 h | 2 h | 24 h |

■ **HANDLING AND STORAGE** Like all building materials, the final quality of the installation depends on the condition in which they are transported, handled and stored. The pipes and fittings will be stored separately on an even area, away from dust and sun. In all cases, take special care to avoid rough handling, impacts and especially with projecting, cutting or heavy objects, particularly in cold weather.

■ **THERMOFORMING** Thermoforming of the GIRAIR® pipes is strictly prohibited on the work site and involves cancellation of the GIRPI guarantee. For all direction changes, make use of standard GIRPI fittings only.

■ CONNECTIONS OF THE GIRAIR FITTINGS ONTO THREADED OR TAPPED METAL COMPONENTS

Fittings that are equipped with threaded or tapped metal components : GAMML, GAEBL, GA4GL have to be used when you want to seal tight with a metallic fitting.

Waterproofness can then be achieved thanks to traditional means but without using non approved cements.

Excluding connection to wall brackets (GAAP reference), obtained by means of tap connectors (GAUR reference), connections of GIRAIR® to metal pipes, fittings and equipment, whether tapped or threaded (tapered or cylindrical), must be made by means of GIRAIR®/metal couplings provided for this purpose.

In no case should the GIRAIR® pipes and fittings be machine threaded inside or outside.

If sockets, elbows, tees or other GIRAIR® fittings are used with the original tapping or threading in the material itself, they will be screwed by hand only the last quarter turn if necessary will be made preferably by strap wrench.

In this case, in order to seal tight, the use of tow or a similar material is **forbidden**, as excessive tightening may provoke severe damage.

To seal, use :

- teflon tape, such as GEB's high density. On male threads, apply 5 layers of tape clock wise, starting from 1st thread,
- silicone paste. Drying time : 24 h. For Ø 1/2" and 3/4", drying time of 3 hours are sufficient.

| SILICONE PASTES | |
|-----------------|------------------|
| BRAND | REFERENCE |
| LOCTITE | SILICOMET JS 533 |
| GEB | FILETPLAST |

Please contact the silicone pastes manufacturer to know the resistance and sealing under pressure of this products

For other references, please contact GIRPI's technical staff.

■ APPROXIMATE QUANTITIES FOR 100 JOINTINGS DEPENDING ON PIPE DIAMETER :

| Ø PIPE | QUANTITY OF GAFIX CEMENT |
|--------------|--------------------------|
| 16 | 125 ml |
| 20 - 25 - 32 | 200 ml |
| 40 - 50 - 63 | 1 liter |
| 75 | 2 liters |
| 90 - 110 | 3,5 liters |

WORK ON PIPES AND FITTINGS INSTALLATION STUDY

■ GENERAL

The evolution in compressed air production technique and tools requires the design of innovative networks. The obtainment of closed loop circuits per types of workshop or per pressure level guarantees greater efficiency and optimum working pressures at all points in the network.

A shallow slope on the manifolds provided for by the rigidity of the GIRAIR® system combined with the installation of a condensate trap (realized with fitting and piping) at each low point, together with the installation of all branches starting upward.

■ BASIC PATTERN

The isometric drawing below is an example and summarizes the basic principles to respect during an installation of compressed air using the GIRAIR® system.

In case of any special problem, please consult us.

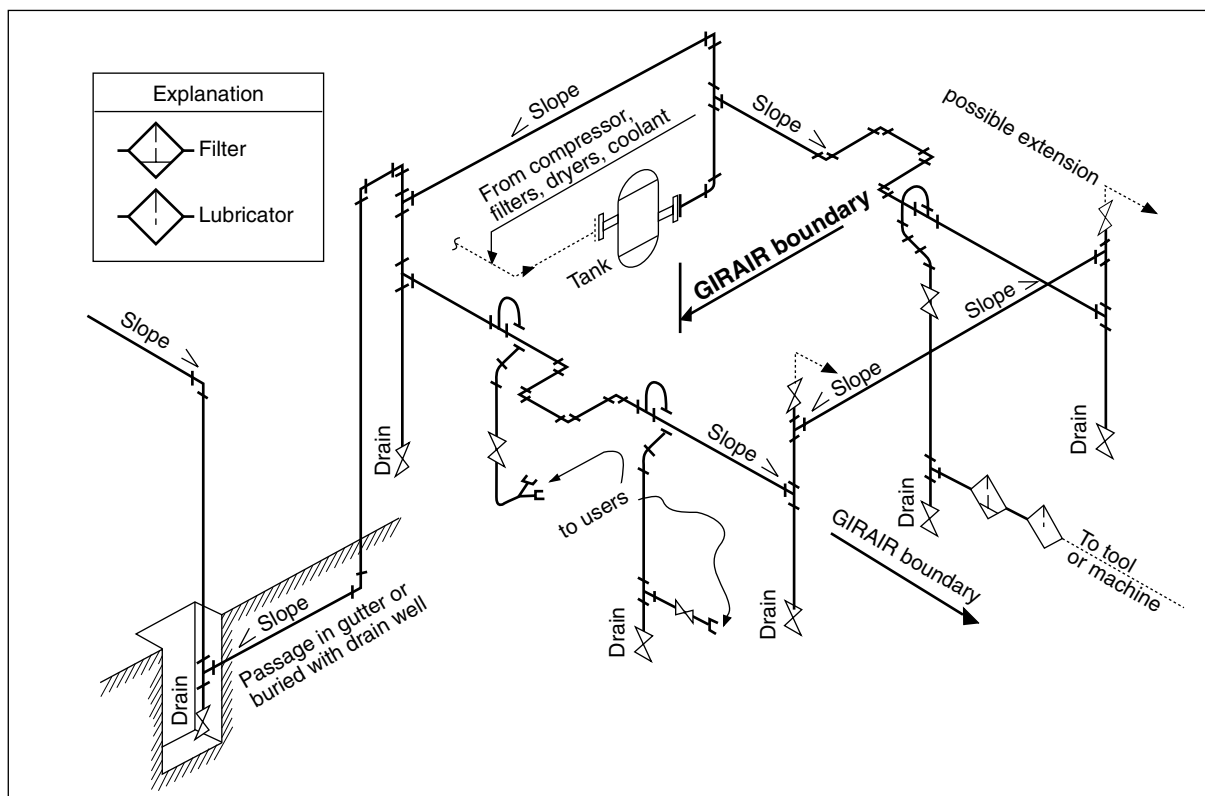

The GIRAIR® system can only be used after the tank, the coolers, etc..., and must not be directly connected to elements subject to strong vibrations.

WORKS ON PIPES AND FITTINGS INSPECTIONS, TESTS AND PUTTING INTO SERVICE

3.6

2002



■ GENERAL :

The GIRAIR® system pipes and fittings are inspected throughout their manufacture and are guaranteed for a use complying with their design within the limits indicated.

During the installation and before putting the GIRAIR® network into service, it is advisable to make a certain number of checks as with all other materials before.

■ INSPECTION :

a) Visual inspection

When assembling, the pipes and fittings should be inspected so as to eliminate doubtful elements containing abnormalities such as impacts and deep scores caused by unsuitable handling. Before the tests, the whole network will be visually inspected to eliminate any part containing deep cuts or notches, large scale deformations due to sudden impacts traces of blow torch burns, etc.... Any damaged part should be replaced before setting into service. The aim of the visual inspection is also to ensure that the installation complies with the drawings and hence the correct installation of all the component parts (connection, supports, monitoring and safety mechanisms, etc...).

b) Leak tests

Before completing the network, a leak test will be made (all parts of the network should be visible and accessible during the test). Consult the DTU 60-31.

■ TEST BEFORE PUTTING INTO SERVICE :

When the leak tests have been made, it is advisable, in order to remove all foreign matter to clean the inside of the network. The test pressure of the circuit will be equal to at least 1,5 times the pressure of service with a maximum of 12,5 bar.

This pressure will be 12 hours long and the manometers should not notice any loss of pressure. The rise of pressure will be done progressively.

The waterproofness of the taps will be checked by closing them, one after the other, and by draining out the pressure downhill slope of each one. At the end of the tests the normal pressure of using should be restored.

■ OPERATING CONDITIONS :

Whatever the case of use, the safety mechanisms necessary for the traditional protection of networks (regulation, anti water hammer, pressure reduction and limitation, temperature regulation and limitation, isolating mechanisms, etc...), should be provided, installed and kept in perfect working order during the operation.

a) Vibrations

Vibrations can be a source of disorders both on the piping and supports ; it is highly advisable to install a suitable system preventing vibration when necessary.

b) Hot sources and UV

Being thermoplastic material, the GIRAIR® system should in no case be installed close to a hot source causing a rise in temperature greater than its limits of use, nor in places continuously exposed to the sun (ultraviolet rays). If this type of installation proves to be inevitable, a minimum number of precautions must be taken such as a protective screen impermeable to ultraviolet or heat rays.

c) Prevention of impacts

As with all networks conveying pressurised fluids, the piping in the GIRAIR® system should be protected against impacts which might occur in places of passage frequented by handling machinery or suspended loads in movement (use of safety barriers, railings, etc...).

CONTRACTION - EXPANSION PHENOMENON - CALCULATION

4.1

■ DIMENSIONAL VARIATIONS

All materials not specially stressed, under the effect of thermal variations in relation to the reference temperature.

■ CALCULATION PARAMETERS FOR THE GIRAIR®

The implementation of the system would take account of the elongation or contraction of the pipe which is calculated by the relation :

$$\Delta L = \alpha \times L \times \Delta T$$

The linear expansion coefficient of the GIRAIR® is : $\alpha = 0,095$ millimeter per meter per °C (mm/m.°C)

in which :

- α = expansion - contraction coefficient (linear)
- L = length of the piping when installed, in meters
- ΔT = temperature deviation in degrees Celsius °C.
(difference between the maximum or minimum temperature in service and installation temperature).
- ΔL = length deviation, in mm
(difference in length between L on installation and L in operation, i.e elongation or shrinkage length).

■ TEMPERATURE OF THE COMPRESSED AIR WHEN CIRCUIT IS IN ORDER

Most of the time the air at the end depends on the temperature of the exterior air aspirated by the compressor, and on dryer if there is one.

Without dryer, the air when it goes out from the compressor, can vary from 20° in winter to 40° in summer.

If in case a refrigerating dryer is used, the usual temperature given at the beginning of the network is 10°C.

Ex 1 : Working network (without dryer)

Ø 63 mm

- Temperature of installation = 20°C
- Temperature of the air when it goes out the compressor = 40°C
- Length (during the installation) = 15 m
- $\Delta T = 40 - 20 = 20^\circ C$
- $\Delta L1 = 0,095 \times 15 \times 20 = 29$ mm in dilatation.

Ex 2 : Working network with a dryer

Ø 63 mm

- Temperature of installation = 25°C
- Temperature of the air at the beginning = 10°C
- Length (during the installation) = 25 m.
- $\Delta T = 25 - 10 = 15^\circ C$
- $\Delta L2 = 0,095 \times 25 \times 15 = 36$ mm of contraction.

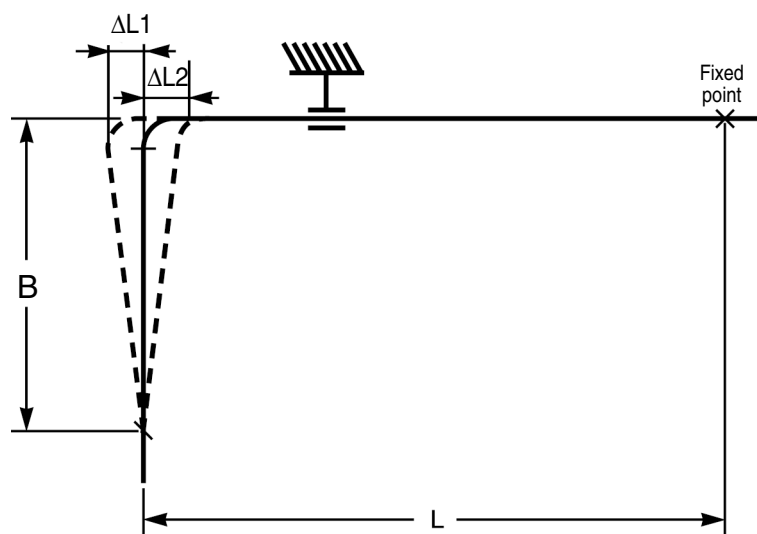

CONTRACTION - EXPANSION CONSEQUENCES

4.2

From the following chart, it is possible to determine the length of B, of the loop when change in direction or branch, depending on the pipe diameter and the movement.

$$B = 34 \sqrt{\varnothing \times \Delta L}$$

\varnothing : External diameter

Δ : Length deviation (in mm)

B : in mm

Ex 1 :

$$B = 34 \sqrt{63 \times 29} = 1,4 \text{ m}$$

Ex 2 :

$$B = 34 \sqrt{63 \times 35} = 1,6 \text{ m}$$

ΔL (mm)

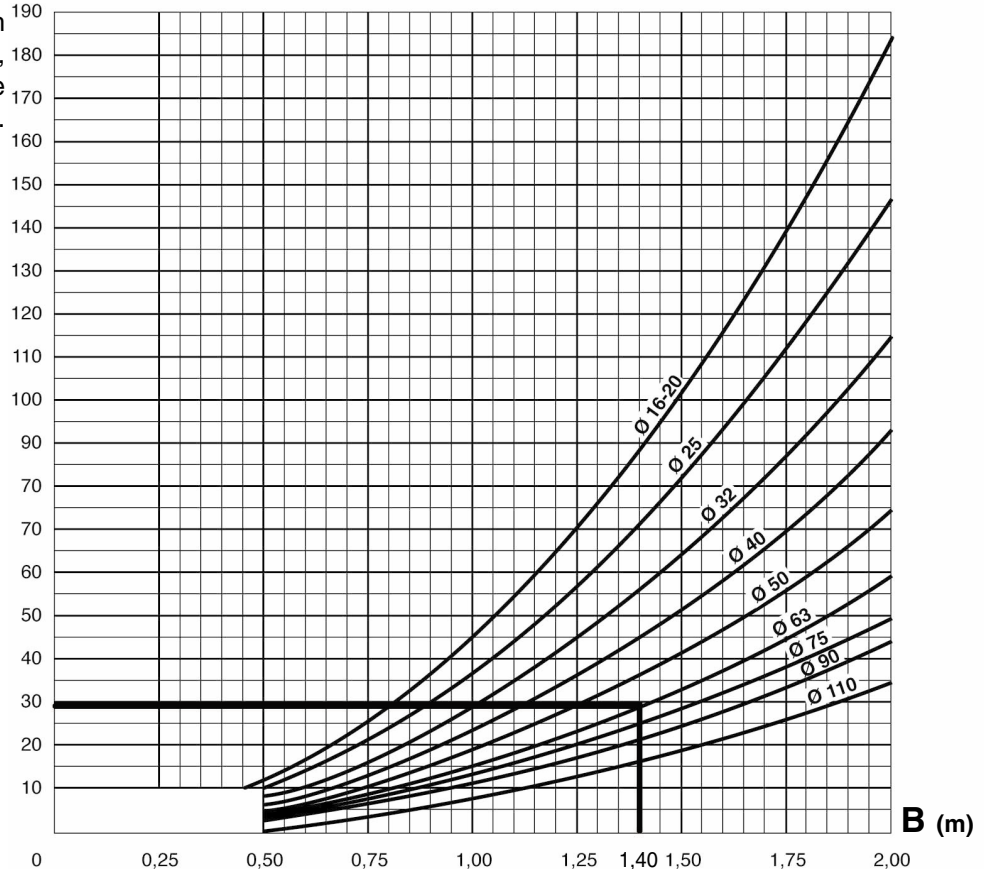

Remedies

As with all changes in directions and branches, the loops are made of pipes and elbows.

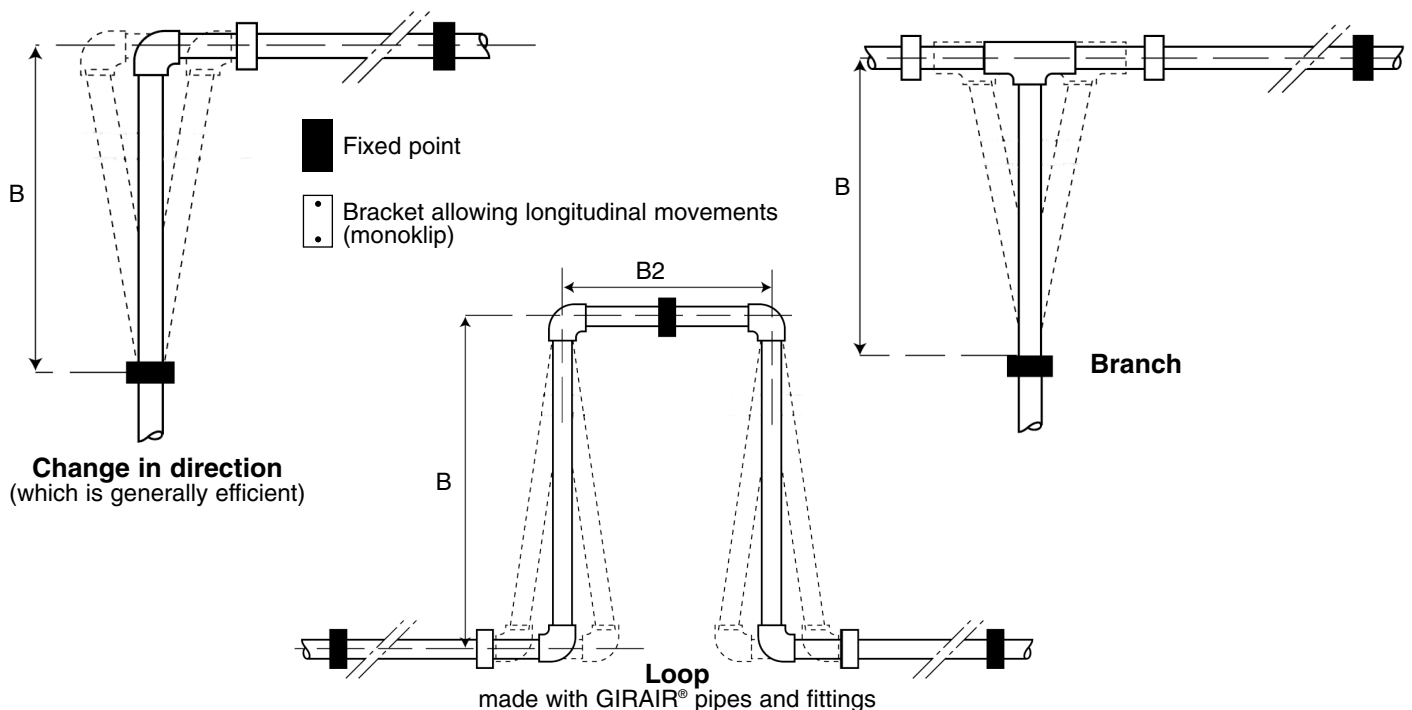

CONTRACTION - EXPANSION CONSEQUENCES

4.3

c) Solutions

To avoid the disorders consecutive to the movements of the pipes, they must be left to expand and contract freely.

It is therefore necessary to :

- Use supports which allow for the longitudinal movements of pipe.
- Ensure that there is never a straight length of pipe between two fixed points, either by using changes in direction, or loops (see illustration below).

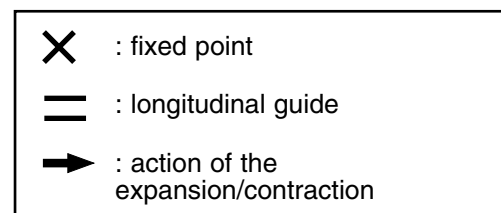
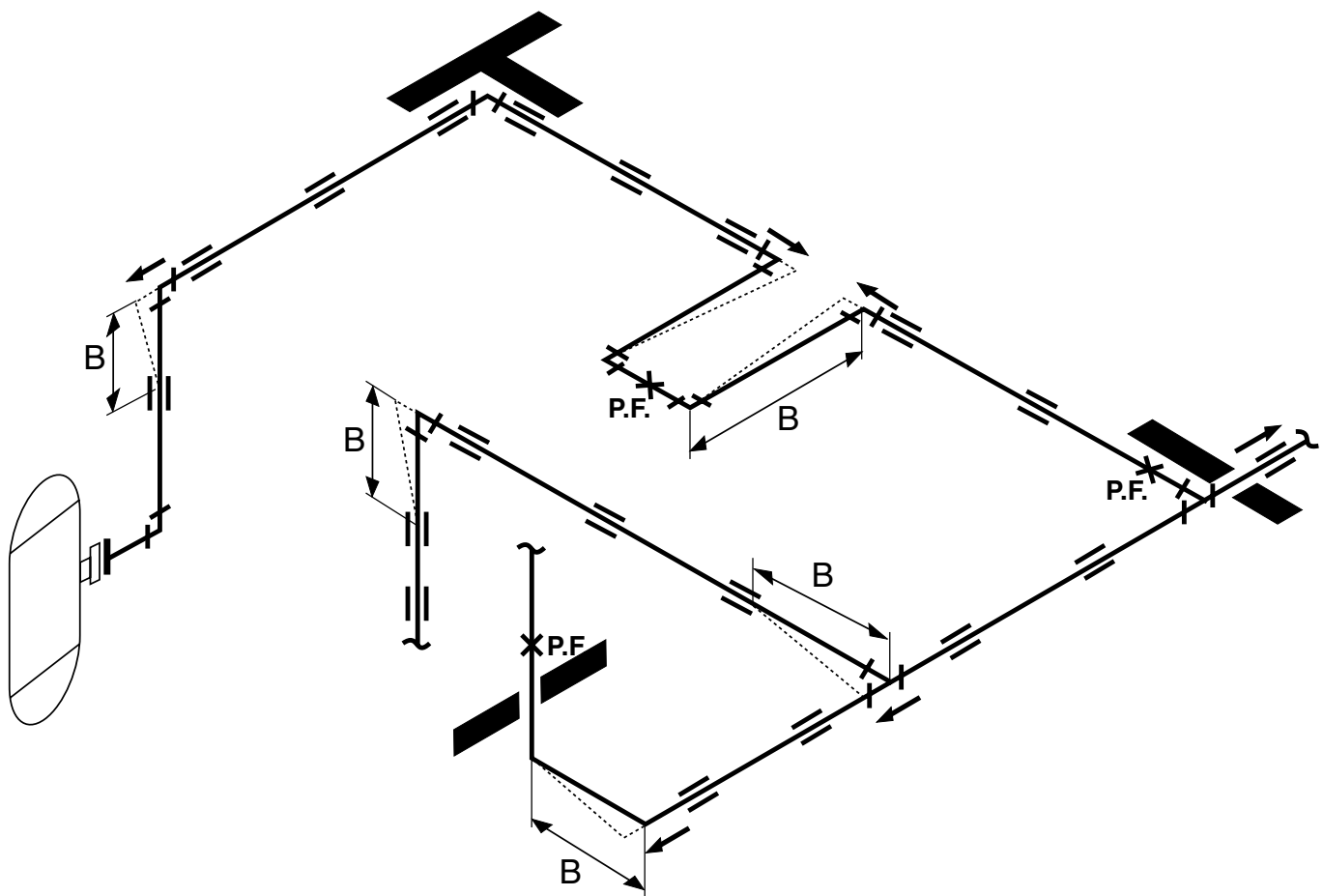

**SUPPORTS
GENERAL - SPACING**

5.1

2002



■ GENERAL

The range of MONOKLIP's has been created especially to support GIRAIR pipes. The MONOKLIPS enable the free expansion or contraction of the pipes.

The supports :

- should continue to support the load they have to support even under temperature effects,
- should leave the pipes free to dilate,
- should continue to support the load that they support sufficiently well away from any wall or obstacle so as to provide for the expansion movements and also the assembly and disassembly of the mechanical couplings and accessories (unions, flanges, valves, pressure limiters, etc...),
- should in no event damage the piping,

Important : Using other supports than MONOKLIP, the pipes may be damaged. In this case a sheath should be added between the support and the pipe in order to prevent it from being pierced.

The pipe must never be tightened and must be free to dilate or contract.

16 to 63 MONOKLIPS have to be over elevated with a 20 mm wedges for brackets that we have designed for this use.
 Réf. CALE 1225 for ø16-25
 CALE 3263 for ø32-40-50-63

■ SPACING OF SUPPORTS :

Spacing between supports have to be chosen in order to avoid the deformation of the pipes. The maximum distances given in the chart below enable to keep the pipes straight taking into account the various diameters.

When heavy accessories, like a tap, are added they need their own supports.

■ SUPPORTS :

| SPACING BETWEEN MONOKLIPS | | | | | | | | | | |
|---------------------------|------|------|------|------|------|------|------|------|------|------|
| Ø | 16 | 20 | 25 | 32 | 40 | 50 | 63 | 75 | 90 | 110 |
| L | 1,05 | 1,15 | 1,30 | 1,40 | 1,60 | 1,85 | 2,10 | 2,30 | 2,50 | 2,80 |

Various accessories or special points require specific supporting : this supporting must be carefully designed in each case to prevent the tube from being subjected to mechanical forces.

| CASE | TYPES OF SUPPORT | REASONS |
|--|---|--|
| ① • GIRAIR® male and female threaded fittings and hose nozzles | Free or fixed on either side (double support) | To avoid tension on threads due to movement out of axis |
| ② • Valves and fittings on pipe and threads | On either side and often with fixed points (double support) | Weight, must operate without twisting |
| ③ • Direction changes | With a brace at right angle | To allow translation of the expansion joint arm, to prevent sag and wear |

IMPORTANT : The sliding supports must be positioned in such a way that the couplings or accessories do not come in contact with them when the pipes expand or contract.

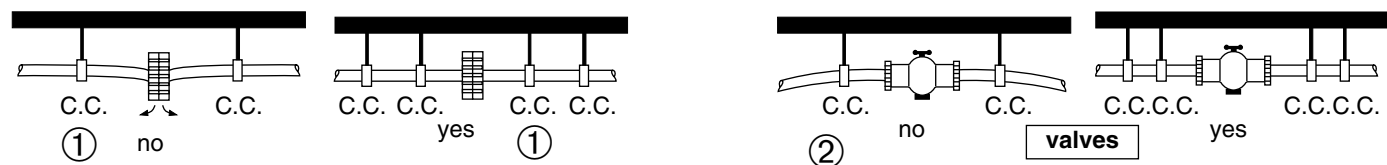

■ **EXAMPLES OF SUPPORTS :**

MONOKLIP brackets

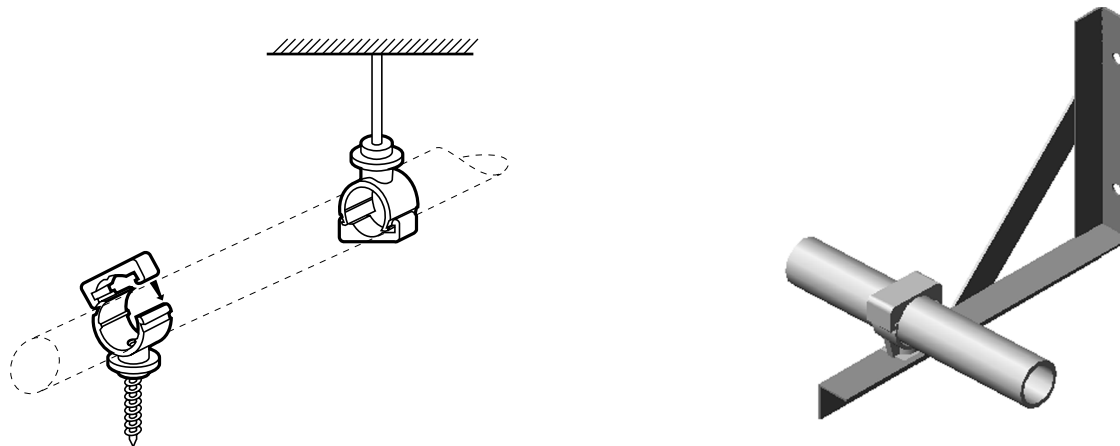

■ **FIXED POINTS**

The saddle pieces are composed of sections of GIRAIR.
The coupling which are cleaned, coated and welded with GAFIX.

• **fixed point on a pipe**

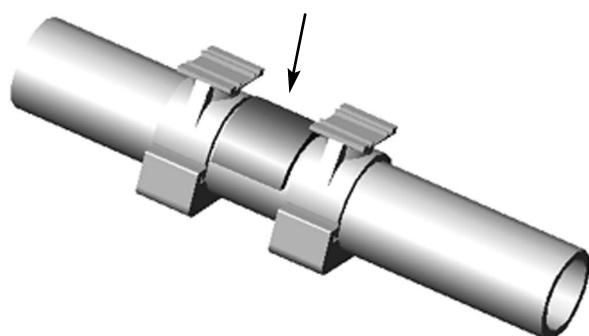

• **fixed on a tee**

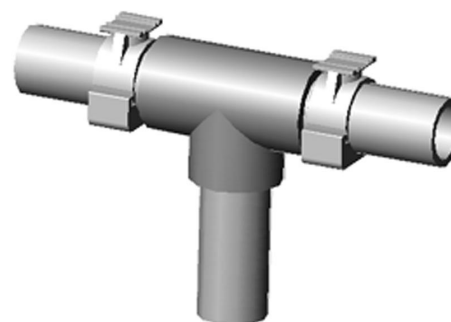

SUPPORTS SPECIAL CASES

5.3

2002



■ Built-in or embedded installation

The GIRAIR® pipes and couplings can be built into or embedded in the masonry on condition that they do not have disconnectable couplings on this part of the circuit.
The following precautions must be respected.

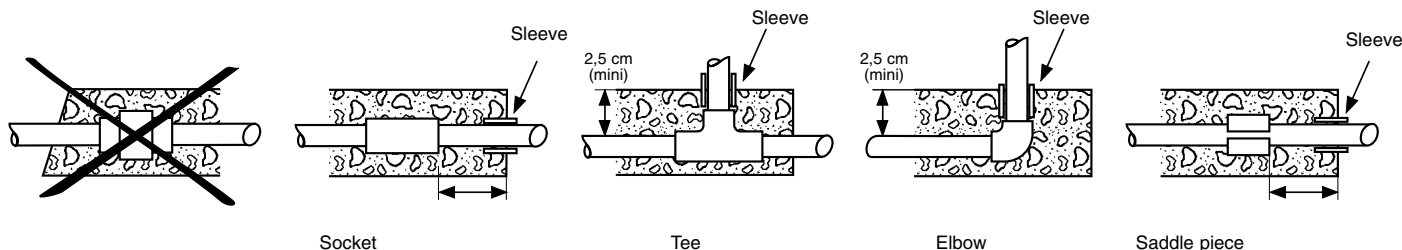

- The pipe must be made integral with the masonry either by means of the couplings making up the system or using saddle pieces bonbed onto the wall of the pipe.
- Each time the pipe enters the masonry it must be protected against shearing by a sleeve which protrudes from the finished surface of the masonry.
- The chase will be filled with an homogeneous material without sharp gravel which could damage the pipe.
- The tests before entry into service must be carried out before filling the chase or pouring the concrete.
- A drain away of the condensation should be foreseen.

■ Buried installation

The GIRAIR® fittings can be buried on condition that the following usual precautions are respected :

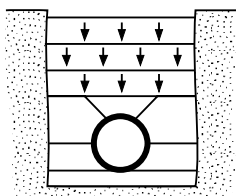

- The bottom of the excavation must be levelled and free of large grained materials and have no surface hard spots.
A carefully compacted bed of 10 cm minimum will be made of clean sand 0/10 containing less than 10 % of fines.
- The backfill directly in contact with the pipe (comprised of sand containing less than 12 % of fines and free of gravel with diameter greater than 30 mm) will cover the pipe to a depth of 15 cm minimum and will be compacted.
- The covering backfill will be compacted in successive layers comprised of materials removed from the trench and which contain less than 30 % of element greater than 20 mm.
- The minimum total height of the backfill above the pipe will be :
 - general case : 60 cm
 - under road/rail traffic : 80 cm
 - under concrete slab : 40 cm



NETWORK CALCULATION

FLOW RATE-PRESSURE LOSSES

6.1

■ NETWORK DESIGN ADVICE

- Have a straight as possible system.
- Compressed air speed should be around 7 m/s : indeed, by exceeding this speed, pressure losses increase so as the energy consumption that is absolutely useless. Nonetheless, a speed inferior to 5 m/s means that the diameter of the pipe is not fully used, and by the way, it enables to regulate the sharp consumption of air thanks to the fluid that is still in the network.
- The network needs to be drained.
- Make branches above the pipes.
- To choose accessoires and fittings that will lead to less pressure losses.
- To design a network as simple as possible to have a better apportionment of the flow.
- Try to have an internal diameter of pipe as constant as possible. To avoid to reduce the section to reduce the pressure losses.
- Use enough valves to allow for network isolation.

■ DRAINING

Condensation has no effect on the GIRAIR® system, but it can damage the production tool. It is important to be able to evacuate condensation and even more if the system does not have a dryer upstream.

- It is preferable to have automatic drains. In the case where it is done manually, a unit with a valve in its extremity at 1,5 m above the ground is needed.
- The network need's a slope from about 0,7 % to 1 % directed toward the valve. The slope will be made in the direction of the flow of the air.
- Drains will have to be done on the lowest levels of the circuit or on the extremity of the straight line.

NETWORK CALCULATION

FLOW RATE-PRESSURE LOSSES

6.2

■ BRANCHES

In order to avoid lead water in the pipe that goes down to the drawing point, branches are done with drop bends above the network.

This technique enables condensation and impurities to be evacuated toward the drains without disrupting the equipment or the manufacturing process (air brush paint with low pressure...).



■ THE FLOW : PRESSURE OF NETWORK

To determine the compressed air network dimensions some points have to be known precisely :

- The equipments using compressed air :
 - quantity,
 - the pressure recommended by the manufacturers,
 - the volume of air consumed when machines are on,
 - number of machines working simultaneously.
- Kind of joins used to link to the compressed air network.
- Identify the accessories added to the compressed air network (filters...).
- To know if the network is forecasted to be extended.
- Consequences on the pressure losses....

The pressure of the network at the beginning has to be equal to the pressure of the machine needing the highest pressure added to the GIRAIR® system load losses, and to particular accessories pressure losses : filters, quick fittings (some of them may have a pressure loss of contact the manufacturer for furttrer information).

Examples :

| | | | |
|--|---|----------------------------|----------------|
| - Screwing machine working with compressed air | = | flow 25 Nm ³ /h | pressure 5 bar |
| - Air brush | = | " 14 Nm ³ /h | " 4 bar |
| - Sandblaster | = | " 35 Nm ³ /h | " 6 bar |

The choice of the diameter of the whole circuit will be done step bystep starting by the main circuit (outflow of the compressor).

NETWORK CALCULATION

FLOW RATE-PRESSURE LOSSES

6.3

EQUIVALENT LENGTH OF PIPE OF THE SAME DIAMETER (in meters)

| Pipe external Ø | Coupling Unions | Elbow 90° | Elbow 45° | Tee | Tee to branch | Reducing bush short pattern | Reducing double long pattern | Bends 90° | 180° drop bends |
|-----------------|-----------------|-----------|-----------|------|---------------|-----------------------------|------------------------------|-----------|-----------------|
| 16 | 0,10 | 0,30 | 0,15 | 0,10 | 0,70 | 0,45 | 0,20 | 0,10 | 0,25 |
| 20 | 0,15 | 0,40 | 0,20 | 0,15 | 0,85 | 0,55 | 0,25 | 0,15 | 0,35 |
| 25 | 0,20 | 0,50 | 0,25 | 0,15 | 1,05 | 0,70 | 0,30 | 0,15 | 0,45 |
| 32 | 0,25 | 0,60 | 0,30 | 0,20 | 1,35 | 0,90 | 0,40 | 0,20 | 0,55 |
| 40 | 0,30 | 0,80 | 0,40 | 0,25 | 1,70 | 1,10 | 0,45 | 0,25 | - |
| 50 | 0,40 | 0,95 | 0,50 | 0,35 | 2,15 | 1,35 | 0,60 | 0,35 | - |
| 63 | 0,50 | 1,25 | 0,60 | 0,45 | 2,70 | 1,70 | 0,75 | 0,45 | - |
| 75 | - | 1,50 | 0,75 | 0,55 | 3,70 | 2,40 | 1,10 | 0,55 | - |
| 90 | - | 1,85 | 0,95 | 0,70 | 4,55 | 3,10 | 1,35 | 0,75 | - |
| 110 | - | 2,50 | 1,35 | 0,95 | 6,05 | 3,50 | 1,55 | 1,00 | - |

We usually add 15 % length more (in meters) for the whole fittings.

Use the above formula to determine the diameter with an optimised fluid speed of **7m/s** :

$$\text{Ø int.} = 10 \sqrt[5,16]{\frac{0,16 \times 10^{-3} Q^2 L1}{\Delta p1 P}}$$

Aubery equation

Ø ins. = inside diameter (mm)

Q = flow (m³/h)

L1 = length (m)

Δp1 = pressure loss of the part (in bar)

P = pressure of the network (in bar)

L1 = Length of pipe + sum of length of the equivalent joins

Note : for a 300 m length circuit if we impose a 0,3 bar Δp

for a 70 m length part $\Delta p = \frac{0,3 \times 70}{300} = 0,07$ bar

Remember : GIRAIR® (mm) pipes dimensions

| Ø ext. | 16 | 20 | 25 | 32 | 40 | 50 | 63 | 75 | 90 | 110 |
|------------|------|------|------|------|------|------|------|------|------|-----|
| Ø int.maxi | 12,4 | 15,4 | 19,4 | 26,2 | 32,6 | 40,8 | 51,4 | 61,4 | 73,6 | 90 |

GIRPI's technical services will answers your questions.

NETWORK CALCULATION

FLOW RATE - PRESSURE LOSSES

- The tables give the pipe outside diameter regarding the pressure losses and the flow rate with a fluid speed about 7m/s.

Pressure = 7 bar

$\Delta p \leq 0,1$

| Q Flow m ³ /h | L1 = Length (m) pipes length + equal length due to the fittings | | | | | | | |
|--------------------------------|--|----|-----|-----|-----|-----|-----|-----|
| | 10 | 25 | 50 | 75 | 100 | 125 | 150 | 200 |
| 25 | 16 | 20 | 20 | 25 | 25 | 25 | 25 | 25 |
| 50 | 20 | 25 | 25 | 32 | 32 | 32 | 32 | 32 |
| 75 | 25 | 32 | 32 | 32 | 32 | 40 | 40 | 40 |
| 100 | 25 | 32 | 32 | 40 | 40 | 40 | 40 | 40 |
| 200 | 32 | 40 | 40 | 50 | 50 | 50 | 50 | 50 |
| 300 | 40 | 50 | 50 | 50 | 63 | 63 | 63 | 63 |
| 400 | 40 | 50 | 63 | 63 | 63 | 63 | 75 | 75 |
| 500 | 50 | 50 | 63 | 63 | 75 | 75 | 75 | 75 |
| 600 | 50 | 63 | 63 | 75 | 75 | 75 | 90 | 90 |
| 700 | 50 | 63 | 75 | 75 | 75 | 90 | 90 | 90 |
| 800 | 50 | 63 | 75 | 75 | 90 | 90 | 90 | 90 |
| 900 | 63 | 63 | 75 | 90 | 90 | 90 | 90 | 110 |
| 1000 | 63 | 75 | 75 | 90 | 90 | 90 | 110 | 110 |
| 1500 | 75 | 90 | 90 | 110 | 110 | 110 | 110 | 110 |
| 2000 | 75 | 90 | 110 | 110 | | | | |

$\Delta p \leq 0,3$

| Q Flow m ³ /h | L1 = Length (m) pipes length + equal length due to the fittings | | | | | | | |
|--------------------------------|--|-----|-----|-----|-----|------|--|--|
| | 300 | 400 | 500 | 600 | 800 | 1000 | | |
| 25 | 25 | 25 | 25 | 25 | 32 | 32 | | |
| 50 | 32 | 32 | 32 | 32 | 32 | 40 | | |
| 75 | 40 | 40 | 40 | 40 | 40 | 40 | | |
| 100 | 40 | 40 | 40 | 40 | 50 | 50 | | |
| 200 | 50 | 50 | 50 | 63 | 63 | 63 | | |
| 300 | 63 | 63 | 63 | 63 | 75 | 75 | | |
| 400 | 75 | 75 | 75 | 75 | 75 | 90 | | |
| 500 | 75 | 75 | 75 | 75 | 90 | 90 | | |
| 600 | 75 | 75 | 90 | 90 | 90 | 90 | | |
| 700 | 90 | 90 | 90 | 90 | 90 | 110 | | |
| 800 | 90 | 90 | 90 | 90 | 110 | 110 | | |
| 900 | 90 | 90 | 90 | 110 | 110 | 110 | | |
| 1000 | 90 | 90 | 110 | 110 | 110 | 110 | | |
| 1500 | 110 | 110 | 110 | | | | | |
| 2000 | | | | | | | | |

Pressure = 12,5 bar

$\Delta p \leq 0,1$

| Q Flow m ³ /h | L1 = Length (m) pipes length + equal length due to the fittings | | | | | | | |
|--------------------------------|--|----|----|-----|-----|-----|-----|-----|
| | 10 | 25 | 50 | 75 | 100 | 125 | 150 | 200 |
| 25 | 16 | 16 | 20 | 20 | 20 | 25 | 25 | 25 |
| 50 | 20 | 20 | 25 | 25 | 32 | 32 | 32 | 32 |
| 75 | 25 | 25 | 32 | 32 | 32 | 32 | 32 | 32 |
| 100 | 25 | 32 | 32 | 32 | 32 | 32 | 40 | 40 |
| 200 | 32 | 32 | 40 | 40 | 50 | 50 | 50 | 50 |
| 300 | 32 | 40 | 50 | 50 | 50 | 50 | 63 | 63 |
| 400 | 40 | 50 | 50 | 50 | 63 | 63 | 63 | 63 |
| 500 | 40 | 50 | 63 | 63 | 63 | 63 | 75 | 75 |
| 600 | 40 | 50 | 63 | 63 | 63 | 75 | 75 | 75 |
| 700 | 50 | 63 | 63 | 63 | 75 | 75 | 75 | 75 |
| 800 | 50 | 63 | 63 | 75 | 75 | 75 | 90 | 90 |
| 900 | 50 | 63 | 75 | 75 | 75 | 90 | 90 | 90 |
| 1000 | 50 | 63 | 75 | 75 | 90 | 90 | 90 | 90 |
| 1500 | 63 | 75 | 90 | 90 | 90 | 110 | 110 | 110 |
| 2000 | 75 | 90 | 90 | 110 | 110 | 110 | 110 | |

$\Delta p \leq 0,3$

| Q Flow m ³ /h | L1 = Length (m) pipes length + equal length due to the fittings | | | | | | | |
|--------------------------------|--|-----|-----|-----|-----|------|--|--|
| | 300 | 400 | 500 | 600 | 800 | 1000 | | |
| 25 | 25 | 25 | 25 | 25 | 25 | 25 | | |
| 50 | 32 | 32 | 32 | 32 | 32 | 32 | | |
| 75 | 32 | 32 | 32 | 32 | 40 | 40 | | |
| 100 | 40 | 40 | 40 | 40 | 40 | 40 | | |
| 200 | 50 | 50 | 50 | 50 | 50 | 63 | | |
| 300 | 50 | 50 | 63 | 63 | 63 | 63 | | |
| 400 | 63 | 63 | 63 | 63 | 75 | 75 | | |
| 500 | 63 | 63 | 75 | 75 | 75 | 75 | | |
| 600 | 75 | 75 | 75 | 75 | 90 | 90 | | |
| 700 | 75 | 75 | 75 | 90 | 90 | 90 | | |
| 800 | 75 | 75 | 90 | 90 | 90 | 90 | | |
| 900 | 75 | 90 | 90 | 90 | 90 | 110 | | |
| 1000 | 90 | 90 | 90 | 90 | 110 | 110 | | |
| 1500 | 110 | 110 | 110 | 110 | 110 | | | |
| 2000 | 110 | 110 | 110 | | | | | |

GIRAIR PIPES

4 m lengths with plain ends

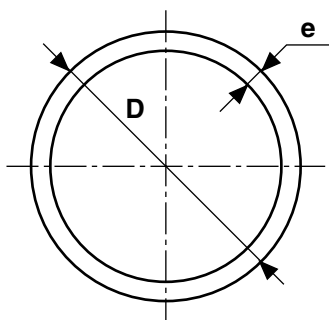

| D | Dn | Reference | Pack (*) | PMS at 25°C | e mini | Weight kg/m | internal Ø | Capacity. l/m |
|-----|-----|-----------|----------|-------------|--------|-------------|------------|---------------|
| 16 | 10 | TUBGA 16 | 10 | 12,5 | 1,8 | 0,106 | 12,4 | 0,120 |
| 20 | 15 | TUBGA 20 | 10 | 12,5 | 2,3 | 0,168 | 15,4 | 0,186 |
| 25 | 20 | TUBGA 25 | 10 | 12,5 | 2,8 | 0,257 | 19,4 | 0,295 |
| 32 | 25 | TUBGA 32 | 10 | 12,5 | 2,9 | 0,340 | 26,2 | 0,538 |
| 40 | 32 | TUBGA 40 | 10 | 12,5 | 3,7 | 0,542 | 32,6 | 0,834 |
| 50 | 40 | TUBGA 50 | 5 | 12,5 | 4,6 | 0,842 | 40,8 | 1,307 |
| 63 | 50 | TUBGA 63 | 1 | 12,5 | 5,8 | 1,334 | 51,4 | 2,074 |
| 75 | 65 | TUBGA 75 | 1 | 12,5 | 6,8 | 2,090 | 61,4 | 2,960 |
| 90 | 80 | TUBGA 90 | 1 | 12,5 | 8,2 | 3,030 | 73,6 | 4,250 |
| 110 | 100 | TUBGA 110 | 1 | 12,5 | 10 | 4,480 | 90,0 | 6,360 |

(*) Number of pipes per bundle

ATTENTION :

- All the sizes indicated in the dimension sheets are in millimeters, when not specified.
- All the threaded fittings are BSP :
 - On CAST IRON, male threads are tapered (conical) and female threads are cylindrical (parallel).
 - On BRASS, male and female threads are cylindrical (parallel).
 - On GIRAIR, male threads are tapered (conical) and female threads are cylindrical (parallel).

IMPORTANT NOTE :

With the constant concern to improve the range and quality of its products with in the context of the standards used at present, GIRPI reserves the right to modify the dimensional characteristics of its pipes and fittings together with the scope of its range, without prior notice.

SOCKET

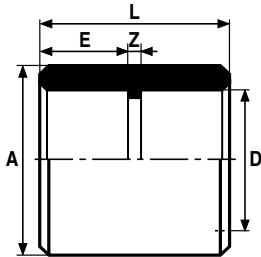

| D | Dn | Reference | Pack | Z | E | L | A | | | |
|-----|-----|-----------|------|-----|------|-----|-----|--|--|--|
| 16 | 10 | GAMA 16 | 10 | 3 | 15 | 33 | 22 | | | |
| 20 | 15 | GAMA 20 | 10 | 3 | 17 | 37 | 26 | | | |
| 25 | 20 | GAMA 25 | 10 | 3 | 19 | 42 | 31 | | | |
| 32 | 25 | GAMA 32 | 10 | 3 | 23 | 49 | 38 | | | |
| 40 | 32 | GAMA 40 | 10 | 3 | 27 | 57 | 47 | | | |
| 50 | 40 | GAMA 50 | 10 | 3,5 | 31 | 67 | 59 | | | |
| 63 | 50 | GAMA 63 | 5 | 4 | 38,5 | 80 | 75 | | | |
| 75 | 65 | GAMA 75 | 1 | 4 | 44,5 | 94 | 90 | | | |
| 90 | 80 | GAMA 90 | 1 | 5 | 52 | 109 | 107 | | | |
| 110 | 100 | GAMA 110 | 1 | 4 | 61,5 | 130 | 132 | | | |

ELBOWS 90°FF

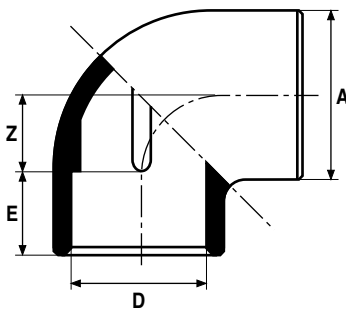

| D | Dn | Reference | Pack | Z | E | A | | | | |
|-----|-----|-----------|------|------|------|------|--|--|--|--|
| 16 | 10 | GA4M 16 | 10 | 8,5 | 15 | 21 | | | | |
| 20 | 15 | GA4M 20 | 10 | 11 | 17 | 25,5 | | | | |
| 25 | 20 | GA4M 25 | 10 | 13,5 | 20 | 31,5 | | | | |
| 32 | 25 | GA4M 32 | 10 | 17 | 23 | 39 | | | | |
| 40 | 32 | GA4M 40 | 10 | 21,5 | 27 | 49 | | | | |
| 50 | 40 | GA4M 50 | 10 | 27 | 32 | 61,5 | | | | |
| 63 | 50 | GA4M 63 | 5 | 32 | 39 | 77 | | | | |
| 75 | 65 | GA4M 75 | 1 | 40 | 44,5 | 92,5 | | | | |
| 90 | 80 | GA4M 90 | 1 | 46,5 | 51,5 | 112 | | | | |
| 110 | 100 | GA4M 110 | 1 | 59 | 62 | 136 | | | | |

ELBOWS 45°FF

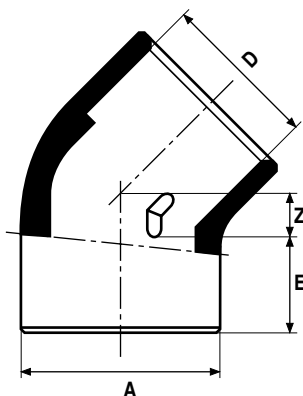

| D | Dn | Reference | Pack | Z | E | A | | | | |
|-----|-----|-----------|------|------|------|-------|--|--|--|--|
| 16 | 10 | GA8M 16 | 10 | 4,5 | 14,5 | 21 | | | | |
| 20 | 15 | GA8M 20 | 10 | 4,5 | 17 | 26 | | | | |
| 25 | 20 | GA8M 25 | 10 | 5,5 | 19,5 | 31 | | | | |
| 32 | 25 | GA8M 32 | 10 | 7,5 | 24 | 39 | | | | |
| 40 | 32 | GA8M 40 | 10 | 9,5 | 28 | 49 | | | | |
| 50 | 40 | GA8M 50 | 10 | 12 | 32 | 61 | | | | |
| 63 | 50 | GA8M 63 | 5 | 15 | 38 | 78 | | | | |
| 75 | 65 | GA8M 75 | 1 | 19,5 | 42,5 | 92 | | | | |
| 90 | 80 | GA8M 90 | 1 | 19 | 52 | 114,2 | | | | |
| 110 | 100 | GA8M 110 | 1 | 24 | 62 | 135 | | | | |

90° BENDS FF

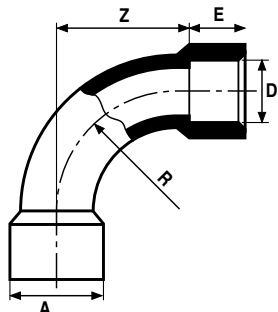

| D | Dn | Reference | Pack | Z | E | A | R | | | |
|-----|-----|-----------|------|-----|----|-----|-----|--|--|--|
| 50 | 40 | GA4C 50 | 10 | 99 | 31 | 64 | | | | |
| 63 | 50 | GA4C 63 | 5 | 127 | 38 | 80 | | | | |
| 75 | 65 | GA4C 75 | 1 | 240 | 62 | 86 | 225 | | | |
| 90 | 80 | GA4C 90 | 1 | 288 | 72 | 103 | 270 | | | |
| 110 | 100 | GA4C 110 | 1 | 352 | 88 | 126 | 330 | | | |

CROSSES 90° - FF

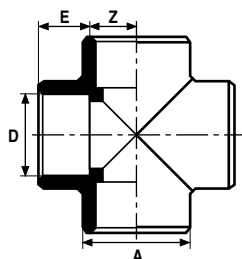

| D | Dn | Reference | Pack | Z | E | A | | | | |
|----|----|-----------|------|----|------|------|--|--|--|--|
| 25 | 20 | GAXT 25 | 1 | 13 | 18,5 | 33,5 | | | | |
| 32 | 25 | GAXT 32 | 1 | 17 | 22 | 40 | | | | |
| 40 | 32 | GAXT 40 | 1 | 21 | 26 | 51 | | | | |

STREET ELBOWS 45° - MF

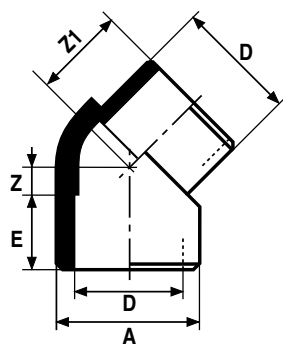

| D | Dn | Reference | Pack | Z | E | A | Z1 | | | |
|----|----|-----------|------|----|----|----|----|--|--|--|
| 16 | 10 | GA8M 16MF | 10 | 9 | 15 | 24 | 24 | | | |
| 20 | 15 | GA8M 20MF | 10 | 10 | 17 | 30 | 27 | | | |
| 25 | 20 | GA8M 25MF | 10 | 6 | 19 | 32 | 25 | | | |
| 32 | 25 | GA8M 32MF | 10 | 12 | 23 | 39 | 34 | | | |

180° DROP BENDS

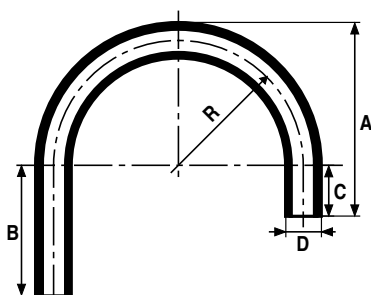

| D | Dn | Reference | Pack | R | A | B | C | | | |
|----|----|-----------|------|----|-------|-----|----|--|--|--|
| 16 | 10 | GA2C 16 | 10 | 64 | 89 | 90 | 17 | | | |
| 20 | 15 | GA2C 20 | 10 | 70 | 100 | 90 | 20 | | | |
| 25 | 20 | GA2C 25 | 10 | 75 | 110,5 | 90 | 23 | | | |
| 32 | 25 | GA2C 32 | 5 | 95 | 138 | 140 | 27 | | | |

TEES 90° EQUAL

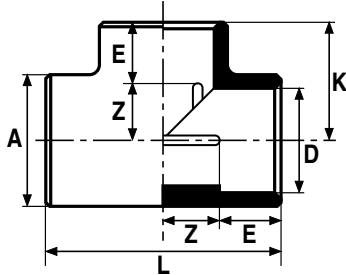

| D | Dn | Reference | Pack | Z | E | L | A | K | | |
|-----|-----|-----------|------|------|------|-------|------|-----|--|--|
| 16 | 10 | GATE 16 | 10 | 9 | 14 | 48 | 21 | 24 | | |
| 20 | 15 | GATE 20 | 10 | 11 | 16 | 56 | 26 | 28 | | |
| 25 | 20 | GATE 25 | 10 | 13,5 | 18,5 | 66 | 31 | 33 | | |
| 32 | 25 | GATE 32 | 10 | 17 | 22 | 82 | 39 | 41 | | |
| 40 | 32 | GATE 40 | 10 | 21,5 | 26,5 | 99,5 | 54 | 49 | | |
| 50 | 40 | GATE 50 | 10 | 26,5 | 31,5 | 118,5 | 62 | 59 | | |
| 63 | 50 | GATE 63 | 5 | 33 | 38,5 | 143 | 80 | 71 | | |
| 75 | 65 | GATE 75 | 1 | 38,5 | 44,5 | 166,5 | 91,5 | 84 | | |
| 90 | 80 | GATE 90 | 1 | 46 | 52 | 195 | 112 | 98 | | |
| 110 | 110 | GATE 110 | 1 | 57 | 61 | 236 | 133 | 118 | | |

TEES 90° REDUCING

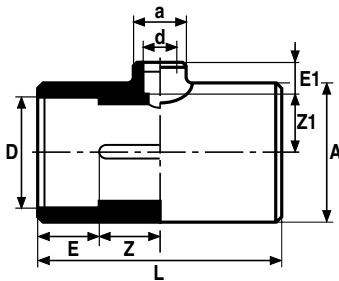

| D-d | Dn | Reference | Pack | Z | Z1 | E | E1 | L | A | a |
|--------|--------|-----------|------|------|------|------|------|-------|-------|------|
| 20-16 | 15-10 | GATR 2016 | 10 | 11 | 11 | 17 | 15 | 56 | 26 | 21 |
| 25-16 | 20-10 | GATR 2516 | 10 | 14 | 14 | 18,5 | 14 | 66 | 31 | 21 |
| 25-20 | 20-15 | GATR 2520 | 10 | 12,5 | 13,5 | 18,5 | 16,5 | 66 | 31 | 26 |
| 32-16 | 25-10 | GATR 3216 | 10 | 17 | 18 | 23 | 14 | 82,5 | 44,5 | 24 |
| 32-20 | 25-15 | GATR 3220 | 10 | 17 | 18 | 23 | 16 | 82,5 | 44,5 | 30 |
| 32-25 | 25-20 | GATR 3225 | 10 | 17 | 19 | 23 | 18,5 | 82,5 | 44,5 | 37 |
| 40-20 | 32-15 | GATR 4020 | 10 | 22 | 23 | 27 | 17 | 99 | 54 | 30 |
| 40-25 | 32-20 | GATR 4025 | 10 | 22 | 23 | 26,5 | 19 | 99 | 54 | 37 |
| 40-32 | 32-25 | GATR 4032 | 10 | 22 | 21 | 26,5 | 23 | 99 | 53,5 | 45 |
| 50-25 | 40-20 | GATR 5025 | 10 | 26 | 27 | 33 | 18,5 | 119 | 62 | 37 |
| 50-32 | 40-25 | GATR 5032 | 10 | 26 | 27 | 33 | 23 | 119 | 62 | 45 |
| 50-40 | 40-32 | GATR 5040 | 10 | 26 | 27 | 33 | 26,5 | 119 | 62 | 53,5 |
| 63-25 | 50-20 | GATR 6325 | 5 | 33 | 32 | 38,5 | 20 | 142 | 80 | 37 |
| 63-32 | 50-25 | GATR 6332 | 5 | 33 | 33,5 | 38,5 | 22,5 | 142 | 80 | 45 |
| 63-40 | 50-32 | GATR 6340 | 5 | 33 | 32 | 38,5 | 27 | 142 | 80 | 54 |
| 75-25 | 65-20 | GATR 7525 | 1 | 38,5 | 38,5 | 44,5 | 19 | 166,5 | 92,5 | 37 |
| 75-32 | 65-25 | GATR 7532 | 1 | 38,5 | 38,5 | 44,5 | 23 | 166,5 | 92,5 | 45 |
| 75-40 | 65-32 | GATR 7540 | 1 | 38,5 | 38,5 | 44,5 | 27 | 166,5 | 92,5 | 54 |
| 90-25 | 80-20 | GATR 9025 | 1 | 45,5 | 46 | 52 | 19,5 | 197 | 112 | 37 |
| 90-32 | 80-25 | GATR 9032 | 1 | 45,5 | 46 | 52 | 23 | 197 | 112 | 45 |
| 90-40 | 80-32 | GATR 9040 | 1 | 45,5 | 46 | 52 | 27 | 197 | 112 | 54 |
| 110-32 | 100-25 | GATR 1132 | 1 | 57,5 | 58 | 62 | 23 | 237,5 | 135,5 | 66 |
| 110-40 | 100-32 | GATR 1140 | 1 | 57,5 | 58 | 62 | 27 | 237,5 | 135,5 | 66 |
| 110-50 | 100-40 | GATR 1150 | 1 | 57,5 | 58 | 62 | 31 | 237,5 | 135,5 | 66 |

REDUCING BUSHES

D : Male, d : Female

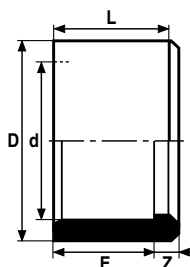

| D-d | Dn | Reference | Pack | Z | E | L | | | | |
|--------|--------|-----------|------|-----|------|------|--|--|--|--|
| 20-16 | 15-10 | GARS 20 | 10 | 2,5 | 15 | 17,5 | | | | |
| 25-20 | 20-15 | GARS 25 | 10 | 3 | 17 | 20 | | | | |
| 32-25 | 25-20 | GARS 32 | 10 | 4,5 | 19 | 23,5 | | | | |
| 40-32 | 32-25 | GARS40 | 10 | 5,5 | 23 | 28,5 | | | | |
| 50-40 | 40-32 | GARS 50 | 10 | 6,5 | 26 | 32,5 | | | | |
| 63-50 | 50-40 | GARS 63 | 5 | 7,5 | 31,5 | 39 | | | | |
| 75-63 | 65-50 | GARS 75 | 1 | 7 | 37 | 44,5 | | | | |
| 90-75 | 80-65 | GARS 90 | 1 | 8,5 | 43,5 | 52 | | | | |
| 110-90 | 100-80 | GARS 110 | 1 | 10 | 52 | 62,5 | | | | |

REDUCERS

D : Male, d et D2: Female (1)

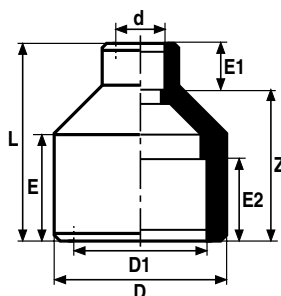

(1) GARD 32 at 110 are Male on reference Ø (D) or Female with a difference of one and Ø female on reduced (d), except for GARD 7532, 7540 and 7550.

| D-d | Dn | Reference | Pack | Z | E | E1 | L | D1 | E2 | |
|--------|--------|-----------|------|------|------|------|-------|-------|------|--|
| 25-16 | 20-10 | GARD 2516 | 10 | 25,5 | 19 | 14,5 | 40 | 16,5 | 14 | |
| 32-20 | 25-15 | GARD 3220 | 10 | 31 | 22,5 | 16,5 | 48 | 25 | 19 | |
| 40-25 | 32-20 | GARD 4025 | 10 | 36 | 27 | 19 | 55,5 | 32 | 22,5 | |
| 50-32 | 40-25 | GARD 5032 | 10 | 44 | 32 | 23 | 66,5 | 40 | 27 | |
| 63-25 | 50-20 | GARD 6325 | 5 | 55 | 39 | 19 | 75 | 50 | - | |
| 63-32 | 50-25 | GARD 6332 | 5 | 55 | 39 | 23 | 78 | 50,5* | - | |
| 63-40 | 50-32 | GARD 6340 | 5 | 55 | 39 | 27 | 82 | 50,5* | - | |
| 75-32 | 65-25 | GARD 7532 | 1 | 62 | 45 | 22,5 | 85 | 61 | 38 | |
| 75-40 | 65-32 | GARD 7540 | 1 | 62 | 45 | 26,5 | 89 | 61 | 38 | |
| 75-50 | 65-40 | GARD 7550 | 1 | 62 | 45 | 31,5 | 93,5 | 61 | 38 | |
| 90-40 | 80-32 | GARD 9040 | 1 | 74,5 | 52,5 | 27 | 101,5 | 75 | 44 | |
| 90-50 | 80-40 | GARD 9050 | 1 | 75 | 52,5 | 31,5 | 106,5 | 75 | 44 | |
| 90-63 | 80-50 | GARD 9063 | 1 | 75 | 52,5 | 38 | 113 | 75 | 44 | |
| 110-50 | 100-40 | GARD 1150 | 1 | 90 | 62 | 32 | 122 | 90 | 52 | |
| 110-63 | 100-50 | GARD 1163 | 1 | 90 | 62 | 38 | 128 | 90 | 52 | |
| 110-75 | 100-65 | GARD 1175 | 1 | 90 | 62 | 44 | 134 | 90 | 52 | |

* Diamètre non normalisé

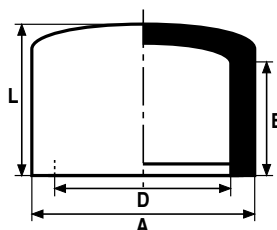
CAPS

| D | Dn | Reference | Pack | E | L | A | | | | |
|-----|-----|-----------|------|------|------|-----|--|--|--|--|
| 16 | 10 | GABO 16 | 10 | 14 | 20 | 24 | | | | |
| 20 | 15 | GABO 20 | 10 | 16 | 23,5 | 30 | | | | |
| 25 | 20 | GABO 25 | 10 | 18,5 | 25,5 | 36 | | | | |
| 32 | 25 | GABO 32 | 10 | 22 | 30 | 44 | | | | |
| 40 | 32 | GABO 40 | 10 | 27 | 37 | 48 | | | | |
| 50 | 40 | GABO 50 | 10 | 33 | 42,5 | 60 | | | | |
| 63 | 50 | GABO 63 | 5 | 39 | 53,5 | 75 | | | | |
| 75 | 65 | GABO 75 | 1 | 61 | 43,5 | 90 | | | | |
| 90 | 80 | GABO 90 | 1 | 53 | 76 | 110 | | | | |
| 110 | 100 | GABO110 | 1 | 61 | 85 | 140 | | | | |

SOCKET UNIONS - With EPDM joint

Female socket - Male socket

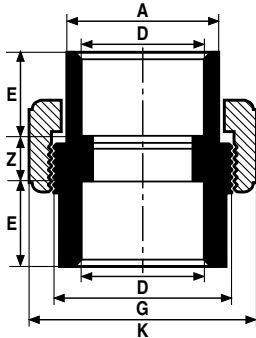

| D | Dn | Reference | Pack | Z | E | A | K | L | | |
|----|----|-----------|------|------|------|------|-------|------|--|--|
| 16 | 10 | GA3P 16 | 10 | 14 | 15 | 22 | 34,5 | 44 | | |
| 20 | 15 | GA3P 20 | 10 | 14 | 16,5 | 27,5 | 42,5 | 47 | | |
| 25 | 20 | GA3P 25 | 10 | 13,5 | 19 | 36 | 54,5 | 51,5 | | |
| 32 | 25 | GA3P 32 | 10 | 14,5 | 22,5 | 41,5 | 62,5 | 59,5 | | |
| 40 | 32 | GA3P 40 | 10 | 15 | 27 | 53 | 75,5 | 69 | | |
| 50 | 40 | GA3P 50 | 10 | 19 | 31,5 | 59 | 83 | 82 | | |
| 63 | 50 | GA3P 63 | 5 | 22 | 38,5 | 74 | 100,5 | 99 | | |

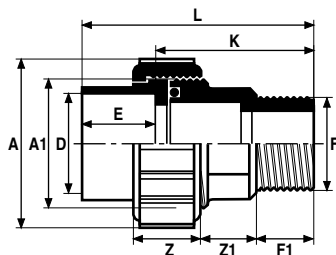
3 PIECE UNIONS - Soc. soc. (with EPDM gasket)

| D | F | Reference | Pack | Z | Z1 | F1 | L | A | A1 | K | E |
|----|-------|-----------|------|----|------|------|-------|-----|-------|------|------|
| 16 | 3/8" | GA3F/P 16 | 5 | 19 | 11,5 | 11,5 | 52 | 36 | 3/4" | 36,5 | 15,5 |
| 20 | 1/2" | GA3F/P 20 | 5 | 22 | 13 | 15 | 60,5 | 44 | 1" | 43 | 17,5 |
| 25 | 3/4" | GA3F/P 25 | 5 | 25 | 18,5 | 16,5 | 71,5 | 56 | 1"1/4 | 52 | 19,5 |
| 32 | 1" | GA3F/P 32 | 5 | 26 | 19 | 19 | 80 | 65 | 1"1/2 | 56 | 24 |
| 40 | 1"1/4 | GA3F/P 40 | 5 | 30 | 18,5 | 21,5 | 87,5 | 76 | 2" | 60 | 27,5 |
| 50 | 1"1/2 | GA3F/P 50 | 5 | 33 | 25 | 23 | 108,5 | 84 | 2"1/4 | 76 | 32,5 |
| 63 | 2" | GA3F/P 63 | 5 | 36 | 25 | 28 | 124,5 | 102 | 2"3/4 | 86 | 38,5 |
| 75 | 2"1/2 | GA3F/P 75 | 5 | 34 | 24 | 30 | 132 | 121 | 3"1/2 | 88 | 44 |

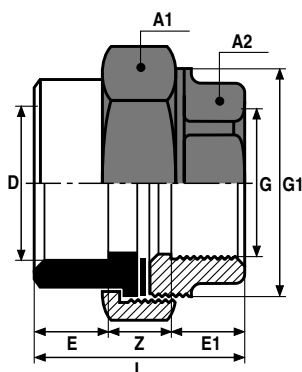
FEMALE COMPOSITE UNIONS - With EPDM gasket - Malleable iron galvanised, BSP parallel Female threaded

| D - G | Dn | Reference | Pack | Z | E | E1 | G1 | A1 | A2 | L |
|----------|----|-----------|------|------|----|----|-------|----|----|------|
| 20-1/2" | 15 | GA3G/F 20 | 5 | 15 | 16 | 17 | 1" | 40 | 25 | 46 |
| 25-3/4" | 20 | GA3G/F 25 | 5 | 13,5 | 19 | 20 | 1"1/4 | 48 | 32 | 52,5 |
| 32-1" | 25 | GA3G/F 32 | 5 | 14,5 | 22 | 24 | 1"1/2 | 53 | 38 | 58,5 |
| 40-1"1/4 | 32 | GA3G/F 40 | 5 | 18 | 26 | 23 | 2" | 68 | 47 | 67 |
| 50-1"1/2 | 40 | GA3G/F 50 | 5 | 19 | 31 | 24 | 2"1/4 | 73 | 54 | 74 |
| 63/2" | 50 | GA3G/F 63 | 5 | 20 | 38 | 30 | 2"3/4 | 87 | 67 | 88 |

Female cast iron, Female GIRAIR

N.B. : The dimensions of the metallic parts may vary according our difference suppliers.

UNIONS MIXTES 3 PIECE

Female composite unions - Malleable iron galvanised, BSP taper Male thread

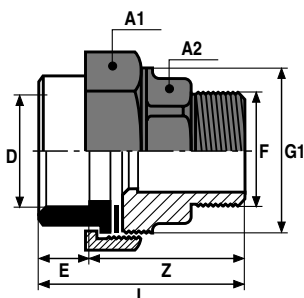

| D- F | Dn | Référence | Cond. | Z | E | L | G 1 | A 1 | A2 | |
|----------|----|-----------|-------|----|----|----|-------|-----|----|--|
| 20-1/2" | 15 | GA3F/F 20 | 5 | 45 | 16 | 61 | 1" | 40 | 23 | |
| 25-3/4" | 20 | GA3F/F 25 | 5 | 46 | 19 | 65 | 1"1/4 | 48 | 27 | |
| 32-1" | 25 | GA3F/F 32 | 5 | 60 | 22 | 82 | 1"1/2 | 53 | 38 | |
| 40-1"1/4 | 32 | GA3F/F 40 | 5 | 65 | 26 | 91 | 2" | 68 | 48 | |
| 50 1"1/2 | 40 | GA3F/F 50 | 5 | 68 | 31 | 99 | 2"1/4 | 73 | 54 | |

N.B. : The dimensions of the metallic parts may vary according our different suppliers.

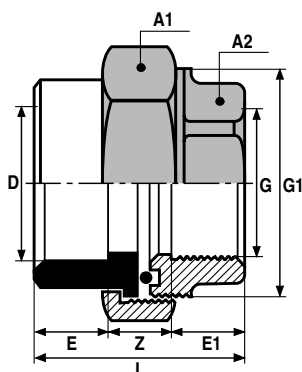
FEMALE COMPOSITE UNIONS

Female brass, Female GIRAIR

| D- G | Dn | Reference | Pack | Z | E | E1 | G1 | A1 | A2 | L |
|-----------|----|-----------|------|----|----|----|-------|----|----|----|
| 16-3/8" | 10 | GA3G/L 16 | 5 | 10 | 14 | 13 | 3/4" | 30 | 27 | 37 |
| 20-1/2" | 15 | GA3G/L 20 | 5 | 13 | 16 | 16 | 1" | 36 | 27 | 45 |
| 25-3/4" | 20 | GA3G/L 25 | 5 | 12 | 19 | 17 | 1"1/4 | 45 | 32 | 48 |
| 32-1" | 25 | GA3G/L 32 | 5 | 14 | 22 | 19 | 1"1/2 | 52 | 38 | 55 |
| 40-1 1/4" | 32 | GA3G/L 40 | 5 | 14 | 26 | 22 | 2" | 66 | 47 | 62 |
| 50-1 1/2" | 40 | GA3G/L 50 | 5 | 13 | 31 | 23 | 2"1/4 | 72 | 53 | 67 |
| 63-2" | 50 | GA3G/L 63 | 5 | 12 | 38 | 27 | 2"3/4 | 89 | 65 | 77 |

N.B. : The dimensions of the metallic parts may vary according our different suppliers.

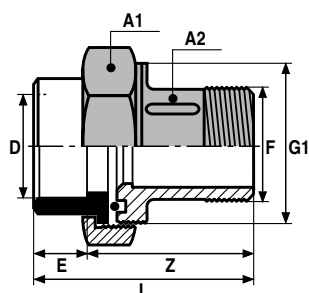
UNIONS MIXTES 3 PIECES - Mâle Laiton, filetage gaz cylindrique, avec joint EPDM

Male brass, Female GIRAIR

| D- F | Dn | Reference | Pack | Z | E | L | G1 | A1 | A2 | |
|----------|----|-----------|------|----|----|-----|-------|----|----|--|
| 16-3/8" | 10 | GA3F/L 16 | 5 | 35 | 14 | 49 | 3/4" | 30 | 17 | |
| 20-1/2" | 15 | GA3F/L 20 | 5 | 39 | 16 | 55 | 1" | 36 | 21 | |
| 25-3/4" | 20 | GA3F/L 25 | 5 | 55 | 19 | 74 | 1"1/4 | 45 | 27 | |
| 32-1" | 25 | GA3F/L 32 | 5 | 60 | 22 | 82 | 1"1/2 | 52 | 35 | |
| 40-1"1/4 | 32 | GA3F/L 40 | 5 | 61 | 26 | 87 | 2" | 66 | 43 | |
| 50-1"1/2 | 40 | GA3F/L 50 | 5 | 69 | 31 | 100 | 2"1/4 | 72 | 49 | |
| 63-2" | 50 | GA3F/L 63 | 5 | 75 | 38 | 113 | 2"3/4 | 89 | 62 | |

UNIONS MIXTES METAL/GIRAIR

Mixed metal/GIRAIR union coupling (tap connectors GIRAIR Male end adaptor)

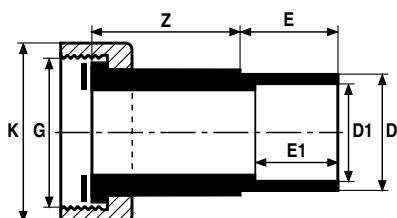

| D-G | Dn | Reference | Pack | Z | E | D1 | E1 | K | | |
|----------|----|-----------|------|----|----|----|------|------|--|--|
| 16-1/2" | 10 | GAUR 16 | 10 | 20 | 15 | 12 | 14 | 24 | | |
| 20-3/4" | 15 | GAUR 20 | 10 | 22 | 17 | 16 | 15 | 29,5 | | |
| 25-1" | 20 | GAUR 25 | 10 | 23 | 20 | 20 | 17 | 36 | | |
| 32-1"1/4 | 25 | GAUR 32 | 10 | 26 | 23 | 25 | 19,5 | 45 | | |
| 40-1"1/2 | 32 | GAUR 40 | 10 | 29 | 27 | 32 | 23 | 52 | | |
| 50-2" | 40 | GAUR 50 | 10 | 31 | 32 | 40 | 26,5 | 66 | | |

FLAT GASKETS EPDM

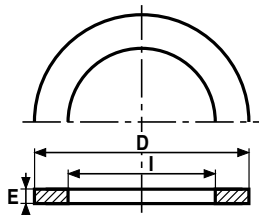

| Reference | Pack | For GAUR | For Mixed Union | For Gacs | D | I | E | | |
|-----------|------|----------|-----------------|----------|-----|-----|---|--|--|
| JPNUR 32 | 1 | 32 | 25 | - | 38 | 27 | 3 | | |
| JPNUR 40 | 1 | 40 | 32 | - | 44 | 32 | 3 | | |
| JPNCS 32 | 1 | - | - | 32 | 48 | 32 | 2 | | |
| JPNUR 50 | 1 | 50 | 40 | - | 55 | 42 | 3 | | |
| JPNCS 40 | 1 | - | - | 40 | 59 | 40 | 3 | | |
| JPNUR 63 | 1 | - | 50 | - | 62 | 46 | 3 | | |
| JPNCS 50 | 1 | - | - | 50 | 71 | 50 | 3 | | |
| JPNCS 63 | 1 | - | - | 63 | 88 | 63 | 3 | | |
| JPNCS 75 | 1 | - | - | 75 | 104 | 75 | 3 | | |
| JPNCS 90 | 1 | - | - | 90 | 123 | 90 | 3 | | |
| JPNCS 110 | 1 | - | - | 110 | 148 | 110 | 4 | | |

BACKING FLANGES PN16, according to DIN 16966

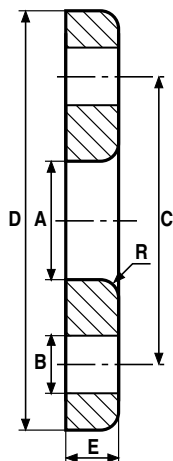

| Pipe Ø | Flange Dn | Reference | Cond. | A | B | C | D | E | R | Nbre of holes | Torque |
|--------|-----------|-----------|-------|------|----|-----|-----|----|-----|---------------|--------------|
| 32 | 25 | BVR 25 | 1 | 42 | 14 | 85 | 115 | 20 | 1,5 | 4 | 0,5 to 1 mkg |
| 40 | 32 | BVR 32 B | 1 | 52 | 18 | 100 | 140 | 20 | 2 | 4 | 2 to 4 mkg |
| 40 | 40 | BVR 40 A | 1 | 54 | 18 | 110 | 150 | 20 | 2 | 4 | 2 to 4 mkg |
| 50 | 40 | BVR 40 B | 1 | 63 | 18 | 110 | 150 | 20 | 2 | 4 | 2 to 4 mkg |
| 50 | 50 | BVR 50 A | 1 | 65 | 18 | 125 | 165 | 22 | 2,5 | 4 | 2 to 4 mkg |
| 63 | 50 | BVR 50 B | 1 | 78 | 18 | 125 | 165 | 22 | 2,5 | 4 | 2 to 4 mkg |
| 63 | 60 | BVR 60 A | 1 | 78 | 18 | 135 | 175 | 22 | 2,5 | 4 | 2 to 4 mkg |
| 63 | 65 | BVR 65 A | 1 | 81 | 18 | 145 | 185 | 22 | 2,5 | 4 | 2 to 4 mkg |
| 75 | 65 | BVR 65 B | 1 | 92 | 18 | 145 | 185 | 22 | 2,5 | 4 | 2 to 4 mkg |
| 75 | 80 | BVR 80 A | 1 | 94 | 18 | 160 | 200 | 24 | 3 | 8 | 2 to 4 mkg |
| 90 | 80 | BVR 80 B | 1 | 110 | 18 | 160 | 200 | 24 | 3 | 8 | 3 to 4 mkg |
| 110 | 100 | BVR 100 | 1 | 133 | 18 | 180 | 220 | 26 | 3 | 8 | 3 to 4 mkg |
| 110 | 110 | BVR 110 A | 1 | 133 | 18 | 190 | 230 | 24 | 3 | 8 | 3 to 4 mkg |
| 50 | 40 | BPA 40 | 1 | 62,5 | 18 | 110 | 150 | 18 | 2,5 | 4 | 3 mkg |
| 63 | 50 | BPA 50 | 1 | 78,5 | 18 | 125 | 165 | 19 | 2,5 | 4 | 3 mkg |
| 63 | 60 | BPA 60 | 1 | 78,5 | 18 | 135 | 175 | 19 | 2,5 | 4 | 3 mkg |
| 75 | 65/60 | BPA 65 | 1 | 92 | 18 | 145 | 185 | 22 | 2,5 | 4 | 4 mkg |
| 90 | 80 | BPA 80 | 1 | 110 | 18 | 160 | 200 | 22 | 2,5 | 8 | 4 mkg |
| 110 | 100 | BPA 100 | 1 | 133 | 18 | 180 | 218 | 24 | 3 | 8 | 5 mkg |

FLANGE - adaptators serrated face

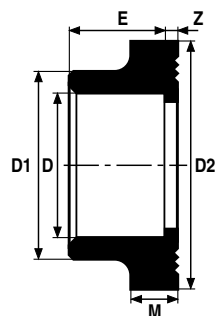

| D | Dn | Reference | Pack | Z | E | D2 | M | D1 | | |
|-----|-----|-----------|------|---|----|-----|----|-----|--|--|
| 32 | 25 | GACS 32 | 10 | 3 | 23 | 50 | 7 | 41 | | |
| 40 | 32 | GACS 40 | 10 | 3 | 27 | 61 | 8 | 50 | | |
| 50 | 40 | GACS 50 | 10 | 3 | 32 | 73 | 8 | 61 | | |
| 63 | 50 | GACS 63 | 5 | 3 | 38 | 90 | 9 | 76 | | |
| 75 | 63 | GACS 75 | 1 | 3 | 44 | 106 | 10 | 90 | | |
| 90 | 80 | GACS 90 | 1 | 5 | 52 | 125 | 11 | 108 | | |
| 110 | 100 | GACS 110 | 1 | 5 | 62 | 150 | 12 | 130 | | |

FEMALE THREADED ADAPTATORS - With metal reinforcing ring

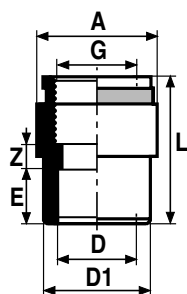

| D-G | Dn | Reference | Pack | Z | E | L | D1 | A1 | Nb Pans | |
|----------|----|-----------|------|----|------|----|----|----|---------|--|
| 16-3/8" | 10 | GAMM 16 | 10 | 5 | 14 | 31 | 20 | 23 | 8 | |
| 20-1/2" | 15 | GAMM 20 | 10 | 5 | 16 | 38 | 25 | 27 | 8 | |
| 25-3/4" | 20 | GAMM 25 | 10 | 5 | 19 | 42 | 32 | 34 | 8 | |
| 32-1" | 25 | GAMM 32 | 10 | 5 | 22 | 48 | 40 | 41 | 8 | |
| 40-1"1/4 | 32 | GAMM 40 | 10 | 11 | 27,5 | 58 | 50 | 55 | 8 | |
| 50-1"1/2 | 40 | GAMM 50 | 10 | 19 | 31 | 64 | 63 | 65 | 8 | |
| 63-2" | 50 | GAMM 63 | 10 | 19 | 32 | 85 | 75 | 70 | 8 | |
| 75-2"1/2 | 65 | GAMM 75 | 10 | 9 | 47 | 88 | 90 | 91 | 8 | |

ELBOWS 90° - Female thread

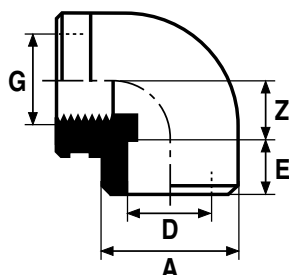

| D-G | Dn | Reference | Pack | Z | E | A | | | | |
|---------|----|-----------|------|----|----|----|--|--|--|--|
| 16-3/8" | 10 | GA4GL 16 | 10 | 9 | 16 | 25 | | | | |
| 20-1/2" | 15 | GA4GL 20 | 10 | 11 | 17 | 29 | | | | |
| 25-3/4" | 20 | GA4GL 25 | 10 | 13 | 19 | 36 | | | | |

TEES 90° - Female thread

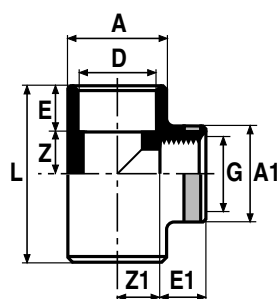

| D-G | Dn | Référence | Cond. | Z | E | L | A | Z1 | E1 | A1 |
|---------|----|-----------|-------|----|----|----|------|------|----|----|
| 16-1/2" | 10 | GATG 1612 | 10 | 9 | 15 | 48 | 25 | 12 | 17 | 35 |
| 20-1/2" | 15 | GATG 2012 | 10 | 12 | 17 | 61 | 30,5 | 11 | 19 | 31 |
| 25-3/4" | 20 | GATG 2534 | 10 | 13 | 19 | 66 | 35 | 13,5 | 22 | 40 |

ADAPTATOR BRUSHES

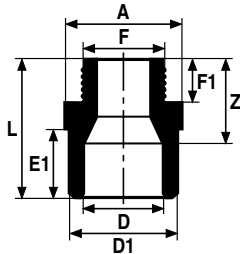

| D | F | Reference | D1 | Z | E | A | L | F1 | Nb sides |
|----|-------|-----------|------|----|------|------|------|------|----------|
| 16 | 3/8" | GAEA 16 | 20 | 24 | 14 | 24,5 | 39 | 12 | 8 |
| 20 | 1/2" | GAEA 20 | 27,3 | 28 | 16,9 | 29,8 | 45 | 14,7 | 12 |
| 25 | 3/4" | GAEA 25 | 32 | 34 | 19 | 37 | 54 | 17 | 12 |
| 32 | 1" | GAEA 32 | 40 | 38 | 22 | 46 | 60 | 20 | 12 |
| 40 | 1"1/4 | GAEA 40 | 50 | 45 | 26,4 | 55,5 | 71,5 | 21 | 12 |
| 50 | 1"1/2 | GAEA 50 | 63 | 46 | 31,5 | 67,5 | 77,5 | 22,5 | 12 |
| 63 | 2" | GAEA 63 | 75 | 48 | 38 | 78 | 86 | 27 | 12 |
| 75 | 2"1/2 | GAEA 75 | 90 | 49 | 45 | 94 | 94 | 30 | 8 |

ADAPTATOR BRUSHES

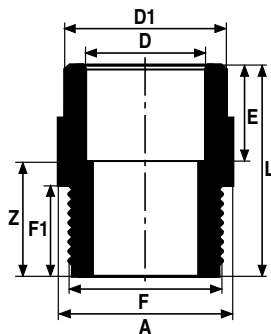

| D | F | Référence | D1 | Z | E | A | L | F1 | Nb pans |
|----|-------|-----------|----|------|----|------|------|------|---------|
| 16 | 1/2" | GAEB 16 | 23 | 27 | 15 | 24,5 | 42 | 14 | 8 |
| 20 | 3/4" | GAEB 20 | 25 | 31 | 17 | 29,5 | 48 | 17 | 12 |
| 25 | 1" | GAEB 25 | 32 | 36 | 19 | 36,5 | 55 | 18 | 12 |
| 32 | 1"1/4 | GAEB 32 | 40 | 40 | 23 | 46 | 59 | 21,5 | 12 |
| 40 | 1"1/2 | GAEB 40 | 50 | 43,5 | 26 | 54,5 | 69,5 | 22 | 12 |
| 50 | 2" | GAEB 50 | 63 | 54 | 32 | 67 | 86 | 27 | 12 |

ALL BRACKETS (brass)

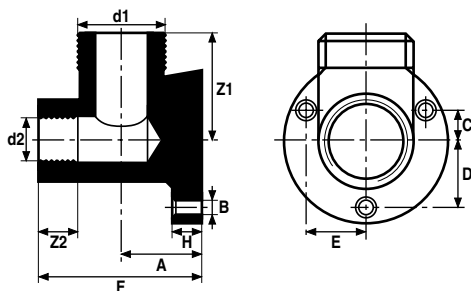

| Tube | Dn | Référence | Cond | D1 | D2 | A | B | Z1 | Z2 | C | D | E | F | G |
|------|----|-----------|------|------|------|------|---|----|-----|---|------|------|------|---|
| 16 | 10 | GAAP 16 | 1 | 1/2" | 3/8" | 19 | 5 | 36 | 6 | 6 | 17,5 | 16,5 | 36 | 5 |
| 20 | 15 | GAAP 20 | 1 | 3/4" | 1/2" | 20,5 | 5 | 38 | 8,5 | 6 | 20 | 19 | 42,5 | 6 |
| 25 | 20 | GAAP 25 | 1 | 1" | 3/4" | 23 | 5 | 40 | 12 | 8 | 25 | 23,5 | 52 | 6 |

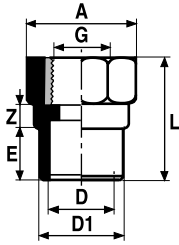
THREADED ADAPTORS (Soc. x female brass thread)

| D-G | Dn | Code | Z | E | L | D1 | A | Nb pans | | |
|---------|----|----------|-----|------|------|----|------|---------|--|--|
| 16-3/8" | 10 | GAMML 16 | 9 | 17 | 38,5 | 20 | 32,2 | 8 | | |
| 20-1/2" | 15 | GAMML 20 | 9 | 16,5 | 44 | 25 | 36 | 8 | | |
| 25-3/4" | 20 | GAMML 25 | 9,5 | 19,5 | 49 | 32 | 41,4 | 8 | | |
| 32-1" | 25 | GAMML 32 | 9,8 | 23 | 56,4 | 40 | 49,6 | 8 | | |

Designed for high torque

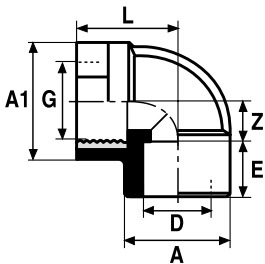
THREADED ELBOWS 90° Soc x Female brass thread

| D-G | Dn | Référence | Z | E | A | A1 | L | | | |
|---------|----|-----------|----|------|----|----|------|--|--|--|
| 16-1/2" | 10 | GA4GL 16 | 12 | 15 | 24 | 36 | 32 | | | |
| 20-1/2" | 15 | GA4GL 20 | 16 | 16,5 | 29 | 36 | 32 | | | |
| 25-3/4" | 20 | GA4GL 25 | 17 | 19,5 | 35 | 41 | 37,5 | | | |

Designed for high torque

ADAPTOR NIPPLES (Brass threaded)

Designed for high torque

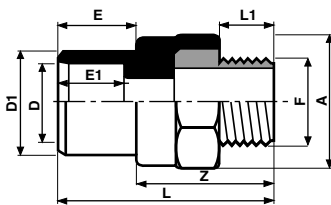

| D-F | Référence | D1 | Z | E | E1 | A | L | L1 | Nombre de pans |
|---------|-----------|----|------|------|------|------|------|------|----------------|
| 16-3/8" | GAEAL 16 | 20 | 32,5 | 17 | 15 | 32,2 | 49,5 | 11 | 8 |
| 20-1/2" | GAEAL 20 | 25 | 41 | 19 | 17 | 36 | 60 | 15 | 8 |
| 25-3/4" | GAEAL 25 | 32 | 43 | 22,5 | 19,5 | 41 | 65 | 16 | 8 |
| 32-1" | GAEAL 32 | 40 | 49 | 27 | 23 | 49,5 | 76 | 19,5 | 8 |
| 16-1/2" | GAEBL 16 | 20 | 36,5 | 16,5 | 14,5 | 32,2 | 53,5 | 13,5 | 8 |
| 20-3/4" | GAEBL 20 | 25 | 43 | 19,5 | 17 | 41 | 62,5 | 16 | 8 |
| 25-1" | GAEBL 25 | 32 | 45,5 | 23 | 19 | 49,5 | 68,5 | 19,5 | 8 |

MONOKLIP BRACKETS in black polypropylene

With metal insert M6, M8 or 7x150

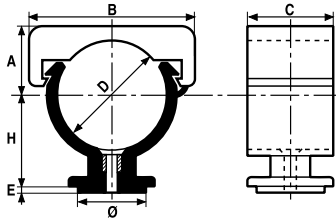

Embase 16 - 25

Use with the wedge
(ref : CALE 1225 height 20 mm).

| D | Dn | Reference | H | A | B | C | Ø | E |
|---------------------|----|-----------|----|----|----|----|----|---|
| WITH INSERT M6 | | | | | | | | |
| 16 | 10 | HCK 16/6 | 18 | 12 | 27 | 20 | 16 | 1 |
| 20 | 15 | HCK 20/6 | 22 | 14 | 32 | 22 | 16 | 1 |
| 25 | 20 | HCK 25/6 | 22 | 16 | 39 | 25 | 16 | 1 |
| WITH INSERT M8 | | | | | | | | |
| 16 | 10 | HCK 16/8 | 18 | 12 | 27 | 20 | 16 | 1 |
| 20 | 15 | HCK 20/8 | 22 | 14 | 32 | 22 | 16 | 1 |
| 25 | 20 | HCK 25/8 | 22 | 16 | 39 | 25 | 16 | 1 |
| WITH INSERT 7 x 150 | | | | | | | | |
| 16 | 10 | HCK 16/7 | 18 | 12 | 27 | 20 | 16 | 1 |
| 20 | 15 | HCK 20/7 | 22 | 14 | 32 | 22 | 16 | 1 |
| 25 | 20 | HCK 25/7 | 22 | 16 | 39 | 25 | 16 | 1 |

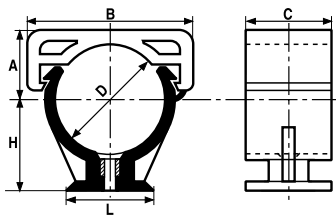

Embase 32 à 63

Use with the wedge
(ref : CALE 3263 height 20 mm).

| D | Dn | Reference | H | A | B | C | L |
|---------------------|----|-----------|----|----|----|----|----|
| WITH INSERT M6 | | | | | | | |
| 32 | 25 | HCKC 32/6 | 28 | 20 | 45 | 25 | 30 |
| 40 | 32 | HCKC 40/6 | 32 | 24 | 55 | 25 | 30 |
| 50 | 40 | HCKC 50/6 | 36 | 30 | 68 | 25 | 52 |
| 63 | 50 | HCKC 63/6 | 40 | 37 | 82 | 25 | 52 |
| WITH INSERT M8 | | | | | | | |
| 32 | 25 | HCKC 32/8 | 28 | 20 | 45 | 25 | 30 |
| 40 | 32 | HCKC 40/8 | 32 | 24 | 55 | 25 | 30 |
| 50 | 40 | HCKC 50/8 | 36 | 30 | 68 | 25 | 52 |
| 63 | 50 | HCKC 63/8 | 40 | 37 | 82 | 25 | 52 |
| WITH INSERT 7 x 150 | | | | | | | |
| 32 | 25 | HCKC 32/7 | 28 | 20 | 45 | 25 | 30 |
| 40 | 32 | HCKC 40/7 | 32 | 24 | 55 | 25 | 30 |
| 50 | 40 | HCKC 50/7 | 36 | 30 | 68 | 25 | 52 |
| 63 | 50 | HCKC 63/7 | 40 | 37 | 82 | 25 | 52 |

PIPE CLIPS in black PEHD

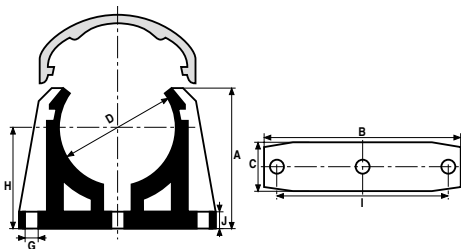

| D | Dn | Reference | Pack | H | A | B | C | G | I | J |
|-----|-----|-----------|------|----|-----|-----|----|-----|-----|---|
| 75 | 65 | A9C 75 | 1 | 63 | 87 | 125 | 30 | 8,5 | 108 | 9 |
| 90 | 80 | A9C 90 | 1 | 72 | 100 | 142 | 30 | 8,5 | 124 | 9 |
| 110 | 100 | A9C 110 | 1 | 84 | 117 | 162 | 30 | 8,5 | 144 | 9 |

BALL VALVES CEMENT SOCKET ENDS

7.13

2002

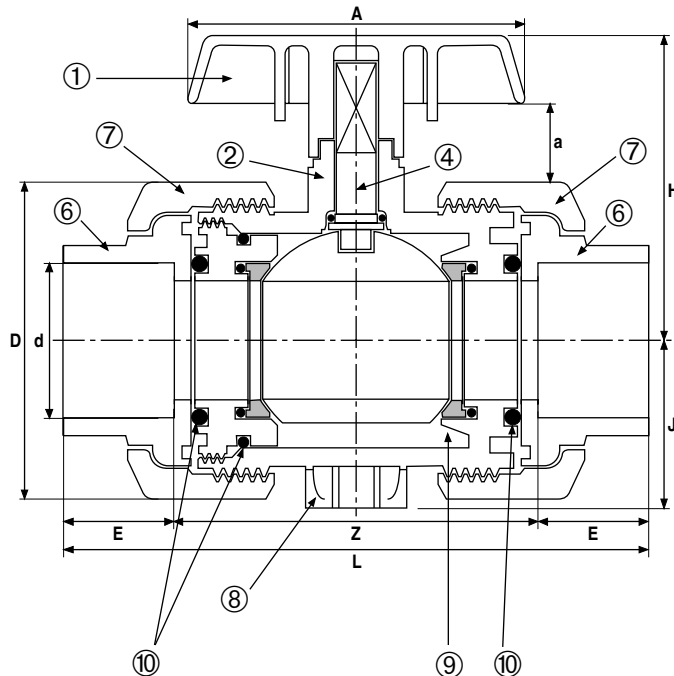
ø 16 to 63

LEGEND

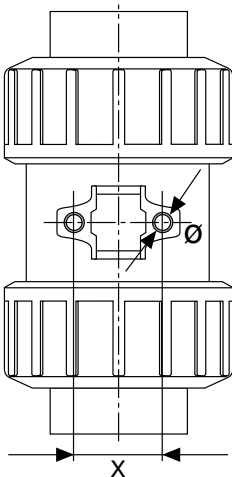
| | | |
|---|-------------------|--------------|
| ① | Handle with lugs | PVC-U (blue) |
| ② | Body | GIRAIR |
| ③ | Ball | PVC-U |
| ④ | Splindle | PVC-U |
| ⑤ | Ball seat support | PVC-U |
| ⑥ | Cement socket end | GIRAIR |
| ⑦ | Nut | GIRAIR |
| ⑧ | Anchoring | Brass insert |
| ⑨ | Ball seat | PTFE |
| ⑩ | O-rings | EPDM |

ANCHORING SYSTEM

| Ball valve Ø | Screw Ø for brass insert | X (mm) |
|--------------|--------------------------|--------|
| 16 | M 4 | 23 |
| 20 | M 4 | 23 |
| 25 | M 5 | 27 |
| 32 | M 5 | 32 |
| 40 | M 6 | 38 |
| 50 | M 6 | 50 |
| 63 | M 6 | 53 |

These ball valves have a built-in anchoring system.

There are two holes underneath fitted with threaded brass inserts (use screw in accordance with data below).

| d | Dn | Reference EPDM | E | Z | L | D | H | A | a | J | Weight Kg |
|----|----|----------------|------|-----|-----|-----|-----|-----|----|----|-----------|
| 16 | 10 | GA2MBE16 | 14,5 | 69 | 98 | 52 | 53 | 77 | 14 | 29 | 0,195 |
| 20 | 15 | GA2MBE20 | 17 | 67 | 101 | 52 | 53 | 77 | 14 | 29 | 0,198 |
| 25 | 20 | GA2MBE25 | 19,5 | 83 | 122 | 81 | 58 | 85 | 14 | 33 | 0,298 |
| 32 | 25 | GA2MBE32 | 22,5 | 86 | 131 | 71 | 70 | 94 | 18 | 38 | 0,426 |
| 40 | 32 | GA2MBE40 | 26,5 | 96 | 149 | 85 | 80 | 110 | 19 | 45 | 0,688 |
| 50 | 40 | GA2MBE50 | 31,5 | 101 | 164 | 101 | 90 | 121 | 20 | 53 | 1,020 |
| 63 | 50 | GA2MBE63 | 38 | 119 | 195 | 121 | 105 | 141 | 23 | 63 | 1,645 |

BALL VALVES CEMENT SOCKET ENDS

7.14

2002



WORKING PRESSURE/TEMPERATURE

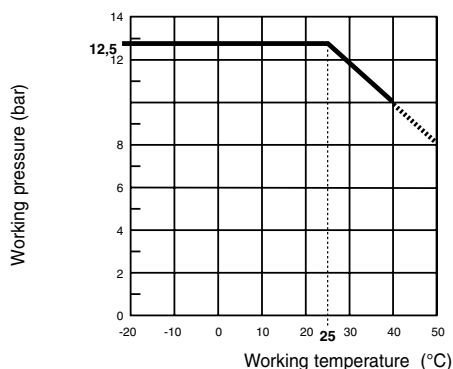

HANDLING TORQUE (PRESSURE 16 BAR)

| Ø | 16 | 20 | 25 | 32 | 40 | 50 | 63 |
|-----------|-----|-----|-----|-----|-----|------|------|
| Torque Nm | 2.0 | 3.0 | 3.0 | 5.0 | 8.5 | 11.5 | 12.5 |

Field of applications :

- the same as that of GIRAIR system.
- max. temperature of use : 45 °C
- max. working pressure (PMS) :
12,5 bar to 25°C.

Assembly:

N.B. : there is an arrow on the valve's body showing the direction of flow (the arrow's head is located close to the fixed ball seat support).

- insert O-ring (9) and PTFE ball seat (8) into their own seats inside the body
- insert the spindle (4), via the inside part of the body, equipped with O-ring (17) in a slot, two PTFE bearings (16 and 15) and an O-ring (14) placed at the spindle's base.
- the spindle's pivot being located in alignment of the valve, place the ball (3)
- fit out the moving ball seat support (5) with the O-ring (9) and the PTFE ball seat (8)
- place the equipped moving ball seat support inside the body (2)
- put O-ring (11) into the front of the slot located between body and moving ball seat support
- assemble flange end with 8 stainless steel bolts including screw (8) washer (12) and nut (13)

Attention : there is a mark on the body of the valve and an other one on the flange end to know the right position of assembly

- assemble the handle (1), taking care to put it correctly with regard to the ball (on spindle's top, a furrow shows the piping's direction).

Diassembling:

- **N.B.** : there is an arrow on the valve's body showing the direction of flow (the moving ball seat support is located on the back side of the arrow).
- put the handle (1) in the closed position of the valve
- unscrew the screws (7)
- remove the flange end (6)
- take off the ball seat support (5) by pulling it out or by pushing the ball by the opposite side with the help of a tool not risking to damage it (take care not to lose the O-ring (11))
- take the ball out (3)
- take the spindle out (4) after removing the handle (1), by pushing it towards the inside of the body (2).

**BALL VALVES
CEMENT SOCKET ENDS**

∅ 75 to 110

| | | |
|---|-------------------|--------------|
| ① | Handle | PVC-U (blue) |
| ② | Body | GIRAIR |
| ③ | Ball | GIRAIR |
| ④ | Spindle | GIRAIR |
| ⑤ | Ball seat support | GIRAIR |
| ⑥ | Cement socket end | GIRAIR |
| ⑦ | Nut | A.I.S.I. 304 |
| ⑧ | Ball seat | PTFE |
| ⑨ | O-rings | EPDM |

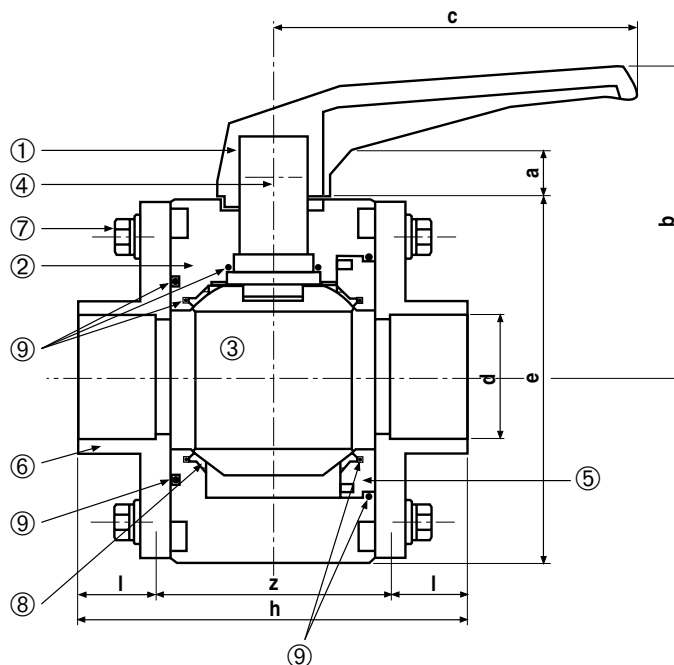

ANCHORING SYSTEM

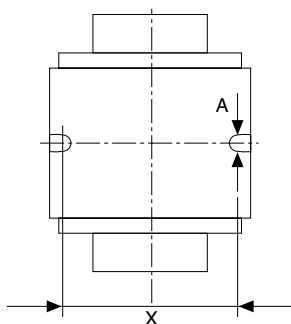

The weight of the ball valves and its correct use require its anchoring on a convenient support.

There are two holes underneath the valve body, which enables you to fix it with bolts on an adapted support.

The table below gives the size of the holes and their spacing.

| ∅ Ball valve | A | X (mm) |
|--------------|----|--------|
| 75 | 11 | 110 |
| 90 | 11 | 110 |
| 110 | 11 | 135 |

| with cement sockets ends | | | l | z | h | e | b | c | a | Mass (kg) |
|--------------------------|-----|-----------|----|-------|-------|-----|-----|-----|----|-----------|
| d | Dn | Ref. EPDM | | | | | | | | |
| 75 | 65 | GA2MFE 75 | 44 | 135 | 223 | 211 | 180 | 209 | 25 | 5,8 |
| 90 | 80 | GA2MFE 90 | 52 | 137,5 | 241,5 | 211 | 180 | 209 | 25 | 5,8 |
| 110 | 100 | GA2MFE 11 | 63 | 159 | 285 | 248 | 220 | 258 | 31 | 9 |

WORKING PRESSURE/TEMPERATURE

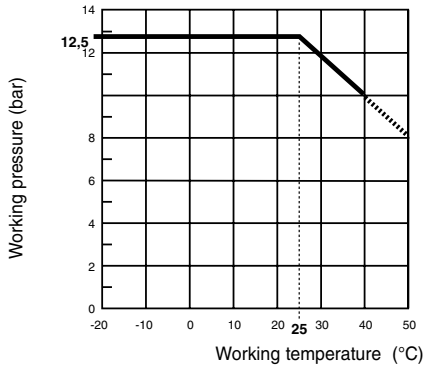

Field of applications :

- the same as that of GIRAIR system.
- max. temperature of use : 45 °C
- max. working pressure (PMS) :
12,5 bar to 25°C.

Assembly:

N.B. : there is an arrow on the valve's body showing the direction of flow (the arrow's head is located close to the fixed ball seat support).

- insert O-ring (9) and PTFE ball seat (8) into their own seats inside the body
- insert the spindle (4), via the inside part of the body, equipped with O-ring (17) in a slot, two PTFE bearings (16 and 15) and an O-ring (14) placed at the spindle's base.
- the spindle's pivot being located in alignment of the valve, place the ball (3)
- fit out the moving ball seat support (5) with the O-ring (9) and the PTFE ball seat (8)
- place the equipped moving ball seat support inside the body (2)
- put O-ring (11) into the front of the slot located between body and moving ball seat support
- assemble flange end with 8 stainless steel bolts including screw (8) washer (12) and nut (13)

Attention : there is a mark on the body of the valve and an other one on the flange end to know the right position of assembly

- assemble the handle (1), taking care to put it correctly with regard to the ball (on spindle's top, a furrow shows the piping's direction).

Diassembling:

- **N.B.** : there is an arrow on the valve's body showing the direction of flow (the moving ball seat support is located on the back side of the arrow).
- put the handle (1) in the closed position of the valve
- unscrew the screws (7)
- remove the flange end (6)
- take off the ball seat support (5) by pulling it out or by pushing the ball by the opposite side with the help of a tool not risking to damage it (take care not to lose the O-ring (11))
- take the ball out (3)
- take the spindle out (4) after removing the handle (1), by pushing it towards the inside of the body (2).



COMPATIBLE OILS CHART

8.1

2002

For the references not listed in the present chart, it is necessary to refer to **GIRPI's technical department**, and ask for approval.

| OILS | |
|--------------------------|---|
| BRAND | REFERENCE |
| AGIP | ACER 46, 100, 150 DICREA 68, 100, 150 DIESEL SIGMA S 10W, 20W, 30, 40 MOTOR OIL HD 10W/20,20W/30,50 OSO 32, 46, 68, 100 OTE 46, 68, 80, 100 |
| AMOCO | AMERICAN INDUSTRIAL OIL 100 ISO VIS COMPRESSOR OIL |
| ANDEROL ITALIA | ANDEROL 3046 ANDEROL 500 |
| ANTAR | MILANTAR 26 10 |
| ARAL | KOSMOL TL (All grades) KOWAL M (All grades) MOTANOL HE (All grades) MOTANOL HK (All grades) MOTANOL HP (All grades) VITAM DE VITAM GF (All grades) VITAM HF (All grades) |
| ATLAS COPCO | ROTOINJECTFLUID |
| AVIA | AVILUBE VD-L 100, 150 MOTOR OIL HD 30 |
| BRITISH PETROLEUM | ENERGOL HLP 32, 46, 68, 100 ENERGOL RC 32, 68, 100 ENERGOL RC-R 32 ENERGOL SHF 32, 46, 68, 100 ENERGOL THB 32, 46, 68, 77, 100 VANELLUS M 10W, 20W, 30, 40 VANELLUS C3 10W, 20W, 30, 50, 15W/40 VANELLUS T40 |
| CASTROL | AGRICASTROL 10, 20, 30, 40, 50 ANDARIN 32, 42, 46 CASTROL AIRCOL PD 32, 68, 100, 150 CASTROL HYSPIIN AWS 22, 32, 100, 150 DEUSOL CR1, 10, 20, 30, 40 DEUSOL CRX 20, 10W/40 PERFECTO T 32, 46, 68, 100 PRODUCT 672/49 MAGNA 68 ALPHASYNT 46 ARCOLINE AIRCOL PD 68 HYSPIIN AWS 46 CRD 30 RX SUPER HYSPIIN AWH 46 TRANSMAX M |

OILS

| BRAND | REFERENCE |
|--------------------|---|
| CENTURY | COMPRESSOR OIL B PWLC TYPE ACA TYPE ACC TYPE ACD TYPE ACE TURBO 10W |
| CHEVRON | EP HYDRAULIC OIL 22, 32, 46, 68 EP INDUSTRIAL 46, 68, 100 DELO 100 SAE 10W, 30, 40 DELO 200E MOTOR OIL 10W, 20W/20, 20W/50, 30, 40 OC TURBINE OIL 32, 46, 68, 100, 150 |
| COFRAN | COFRAJAH COFRAJAH S TURBICOF |
| COMPAIR | ML 73 |
| CONDAT | HYDROLUB H 32 |
| CREYSSENSAC | ROTAIR 3000 ALTAIR 2000 |
| DEVILBISS | COMP OIL |
| ELF | DACNIS P 32, 68, 100,150 DACNIS VS 150 SERIES 3 ENGINE OIL SPORTIGRADE 15W/40 POLYTELIS 32, 46, 62, 68, 100, 150, 220, 320, 460, 680 |
| ESSO | COMPRESSOR OIL RS32, RS68 ESSOLUBE HDX PLUS 10W, 20W/20, 30,20W/30 ESSOLUBE HDX 40 EXTRA MOTOR OIL 10W/30, 20W/50 KOMPRESSOREL 30, 40 NURAY 22, 150 NUTO H22, 32, 46, 68, 100 PLUS MOTOR OIL 10W, 20W/20, 30, 40 SPINESSO 22, 32 SUPERLUBE 10W/40 TERESSO 32, 46, 68, 77, 100, 150, 220, 320, 46 TERESSO EP 46 UNIFARM 15W/30 UNIFLOW 15W/50, 10W/40 VERDICHTEROEL 3020, 3021N, 3022N ZERICE S-100 |
| FENWICK | HYDROVANNE 2000 OIL |



COMPATIBLE OILS CHART

8.3

2002

OILS

| BRAND | REFERENCE |
|------------------------|--|
| FINA | BAKOLA (All grades) CIRCAN (All grades) DEITA PLUS (All grades) EOLAN AC (All grades) EOLAN DCL (All grades) HYDRAN (All grades) LHM SOLCO (All grades) |
| FUCHS | RENOLIN B (All grades) RENOLIN DTA (All grades) RENOLIN MR (All grades) RENOLIN 104L RENOLIN 504 |
| GULF | COMPRESSOR OIL 32, 68, 100 HARMONY AW (All grades) HYDRASIL (All grades) MECHANISM LP (All grades) |
| HAFA | STATEX 150 |
| INGERSOLL RAND | FOOD GRADE COOLANT SSR ULTRA COOLANT XL T 30 |
| LABEL | IRINA 32 VG |
| MACO MEUDON | MACO-H46 MACO X OIL |
| MANNESMAN DEMAG | HUIL. SPE. COMP. VIS |
| MATTEI | ROTOROIL 2000 |
| MOBIL | ALMO 527 DELVAC 1240, 1310, 1110 DTE HEAVY DTE HEAVY MEDIUM DTE LIGHT DTE MEDIUM DTE 22, 24, 25, 26 ED 62/170 HD OIL 100 RARUS SHC 924 RARUS 424, 425, 427 RARUS 827, 829 |
| MOTUL | SAFCO CPS 100 |
| OPAL | HYDROPAL HO 160 TRANSOPAL TM 03 |



COMPATIBLE OILS CHART

OILS

| BRAND | REFERENCE |
|------------------|--|
| SHELL | COMPTELLA 46 CORENA H68, 100,150 CORENA 37 CORENA P 68 Puissance 5 Moteur essence Puissance 7 Diesel RIMULA X 10W, 30, 40, 50, 15W/40 RIMULA 10W, 20/20W, 30, 40, 50 ROTELLA X 20W/40, 10W, 20/20W, 30, 40 TALPA 20 TELLUS C 32, 46, 68, 100 TELLUS R 37, 46, 68 TELLUS S 32, 37, 46, 68 TELLUS T 15, 22, 37, 46, 68, 100 TELLUS 22, 32, 37, 46, 68, 100 TURBO T 32, 46, 68, 100 TONNA T 22 Q TONNA T 220 |
| SULLAIR | LLL4 24 KT |
| TEXACO | COMPRESSOR OIL VD-L46, 100, 150 COMPRESSOR OIL VW 460 HAVOLINE RANDO HD 32, 46, 68, 150 REGAL R 032, 46, 68, 100, 150 URSATEX 10W, 20W/20, 30, 40 |
| TOTAL | AZOLLA 10, 22, 32, 46, 68, 100 CORTIS EP 46, 100, 150 CORTUSA 32, 46, 68, 100, 150 HD3C 10 W RUBIA H 10W EQUIVIS ZS 46 AZOLLA ZS 32 PRESLIA 46 CORTUSA SY 150 RUBIA H30 CORTUSA SR 100 RUBIA H 10 CORTUSA SR 46 CORTUSA 100/150 |
| VALVOLINE | ETC LIGHT ETC 30 TURBINENOL 2S, 3S |
| WITCO | DEESOLINE HDX-2 RDN 130 RDN 130R RDN 65H |

TECHNICAL SPECIFICATION AND IMPLEMENTATION

Material technical specification :

The pipes and fittings must be from the GIRPI GIRAIR® system or equivalent.

When needed, the manufacturer must be able to provide professional training courses on their premises.

Assembly of GIRAIR® pipes and fittings :

Please refer to guidelines 60.31 & 60.33 and to the manufacturer's current technical documentation.

The pipes shall be exclusively jointed by cold welding :

- cut pipe with plastic pipe cutters,
- trim and chamfer with chamfering tool,
- do not scour with D 171 Plus cleaner **if pipes and fittings are clean and dry.**
- bond with cement (GAFIX) using an adapted brush.

Implementation, contraction :

- Alpha coefficient 0,095 mm/m/ °C.

Linear variations between fixed points shall be absorbed by :

- changes in direction,
- expansion loops made from pipes and fitting.

More Service From GIRPI

Your problem is ours. Training centre, analysis of your needs, specification work, adaptation and, development of specific fabricated products are daily services offered to facilitate sales and installation of our products.

① - NETWORK DESIGN

Our technical assistance and design service can help optimize network drawings, and assist on job sites to help with installation rules.

In the U.K., please call 44 87 0010 4225 for technical assistance. In other countries, please call your usual export contact at Girpi.

② - TRAINING CENTRE

Our training centre (officially recognized for vocational training) gives installers and decision makers modular training courses about installation techniques.

③ - CUSTOM-MADE ITEMS

Our fabrication workshop can manufacture your special items as per your requirements, and can also prefabricate pipework sections.

Please consult us for prices and deliveries.



safety for your pipeworks

Siège Social :

GIRPI

B.P. 36 - Rue Robert Ancel

76700 Harfleur - France

Tél : 02 32 79 60 00 - Fax : 02 32 79 60 27

EXPORT : 33 (0)2 79 66 03 - Fax : 33 (0)2 32 79 60 28

www.girpi.fr - www.girpi.com

export@girpi.com



Stockist